

TOP VIEW

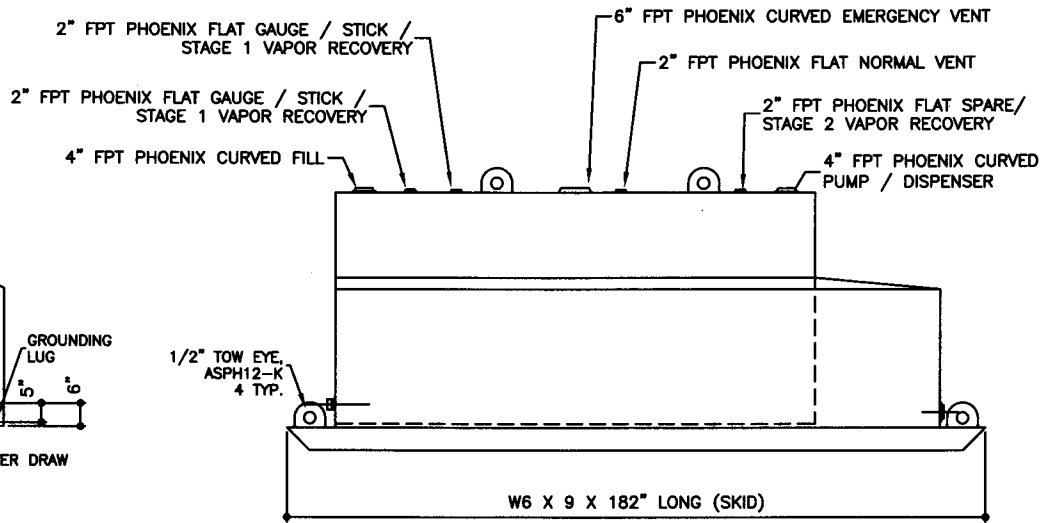

ELEVATION - SIDE VIEW

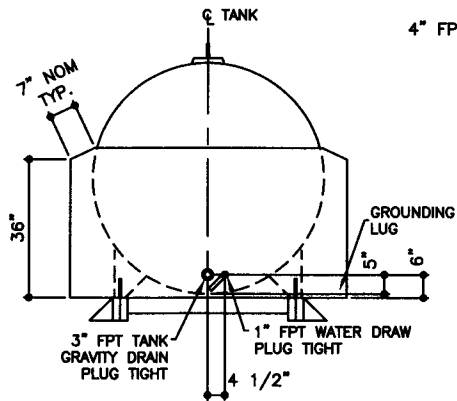

ELEVATION - END VIEW

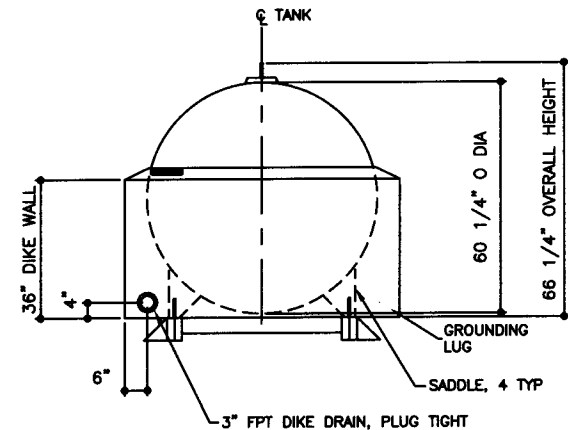

ELEVATION - END VIEW

TOLERANCES	
TANK	
CAPACITY	-0% / +10
OVERALL LENGTH	-0" / +2"
OVERALL WIDTH	-0" / +1"
OVERALL HEIGHT	-1/2" / +1/2"
OTHER DIMENSIONS	-1/4" / +1/4"

UL 142 (BUILT & LABELED)  
HOLDDOWNS ARE SEISMIC RATED  
DIKE TANK WITH SKID

STEEL: ASTM A36  
PRIMARY TANK  
SHELL: 6 GAUGE (3/16")  
HEAD: 6 GAUGE (3/16")

COATING:  
"R" EXTERIOR COATING, ACE 1A  
RED SHOP COAT 1-3 MILS  
"A" EXTERIOR ACE 3A COATING:  
SP-6 GRIT BLAST  
3A COLOR: #WH01 (WHITE)  
1 CT TN-161 EPOXY 3.0-5.0 MILS  
1 CT TN-74 URETHANE 2.0-3.0 MILS  
TDFT 5.0-8.0 MILS

SPECIAL INSTRUCTIONS  
PLUG TIGHT  
WRENCH PLUG TIGHT WITH PIPE DOPE  
ON THREADS AND TESTED LEAK FREE.  
STIFFENERS ARE NOT SHOWN IN  
ELEVATION VIEWS FOR CLARITY

APPROXIMATE SHIPPING WEIGHT  
3,825 LBS.  
TANK VENT CAPACITY  
168,000 PRIMARY

DRW BY  
REV No  
1  
SHEET  
2  
OF



**AceDike - 1,500 GALLON**

ACE PART No: AC01500U2D2 QTY: 1  
(F:111ACSHOPDIKEU2D2I01500I2-ORTH.GCD-1:32)

DIKE TANK  
FLOOR: 10 GAUGE (9/64")  
WALL: 10 GAUGE (9/64")  
COWLING: 10 GAUGE (9/64")

INTERIOR:  
BARE STEEL

JOB ID No: ACE HOUSE PAPER No: ENG. FILE No:

01-01-02 SUPERCEDES 09-01-01

# BILL OF MATERIAL

NOTE:  
1. ALL NOMINAL DIMENSIONS ARE 2"±

ITEM	QTY	NAME	DESCRIPTION	MATL	PART No.	NOTES
1	2	SKID BEAM	W6 X 9 X 182" LONG	A36	-	MOUNT, COAT
2	-					
3	-	SKID CAP	PLATE	-	-	MOUNT, COAT
4	2	SKID CROSS BRACE	L4 X 4 X 3/8 X 43 9/16" LONG TOE DOWN COPE ENDS	A36	-	MOUNT, COAT
5	-	SEISMIC HOLD DOWN	PLATE	A36	-	MOUNT, COAT
6	-	TOW EYE	PLATE	A36	-	SEE DTL SHT

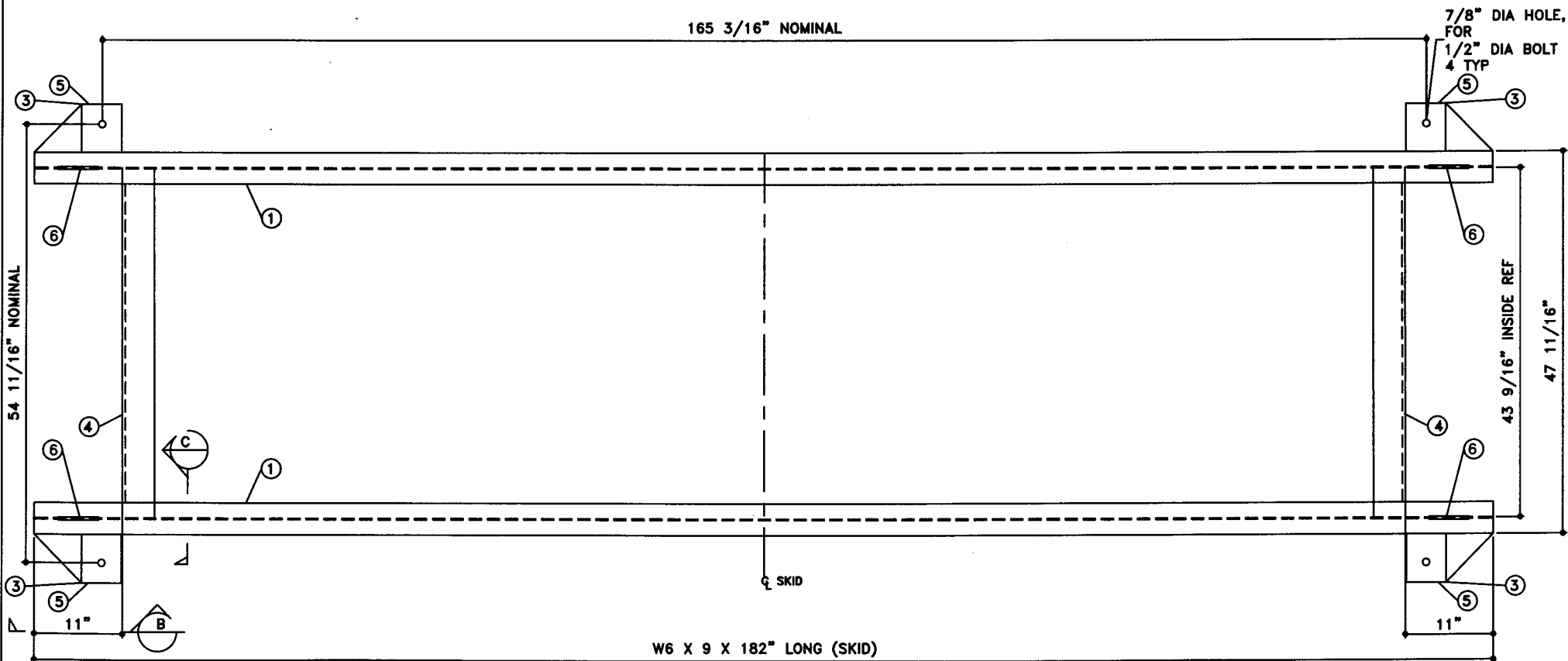

W6 X 9 X 182" LONG (SKID)

## TOP VIEW

**Acetank & Equipment**  
P.O. Box 9039  
Seattle, WA 98109-0039

JOB ID No.	TOLERANCES
-	SKID
ACE HOUSE PAPER No.	OVERALL LENGTH -1/4" / +1/4"
ENG. FILE No.	OVERALL WIDTH -1/4" / +1/4"
-	OVERALL HEIGHT -1/4" / +1/4"
-	OTHER DIMENSIONS -1/8" / +1/8"

QUANTITY	PART NAME	SKID DETAILS
1		
	ACE PART No.	AC01500U2D2
	(1:12)	

No.	DRAWING / REVISION	DRAWN BY	CHECKED BY	SHEET
1	1ST SUBMITTAL	-	-	OF
-	-	-	-	
-	-	-	-	
-	-	-	-	

01-01-01 SUPERCEDES