

4" FPT PHOENIX CURVED SPARE/STAGE 2 VAPOR RECOVERY

3" FPT PHOENIX CURVED NORMAL VENT/
STAGE 1 VAPOR RECOVERY

18" ID PRODUCT FILL MANHOLE

3" FPT FULL CPLG LOWFILL OPENING

3/4" FPT FULL CPLG RETURN

4" FPT PHOENIX FLAT INSPECTION OPENING

4" FPT PHOENIX CURVED
PUMP/DISPENSER

C4 X 5.4 X 90"
LONG, 2 TYP

1/2" TOW EYE,
ASPH12-K
4 TYP.

EMERGENCY VENT
8" SLIP-ON FL 150# RF
SCH 40 X 7" LONG PIPE

4" FPT PHOENIX CURVED GAUGE

2" FPT PHOENIX FLAT STICK

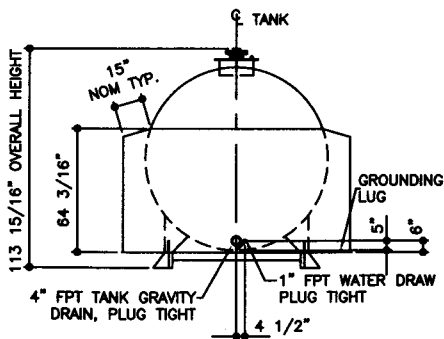

ELEVATION - END VIEW

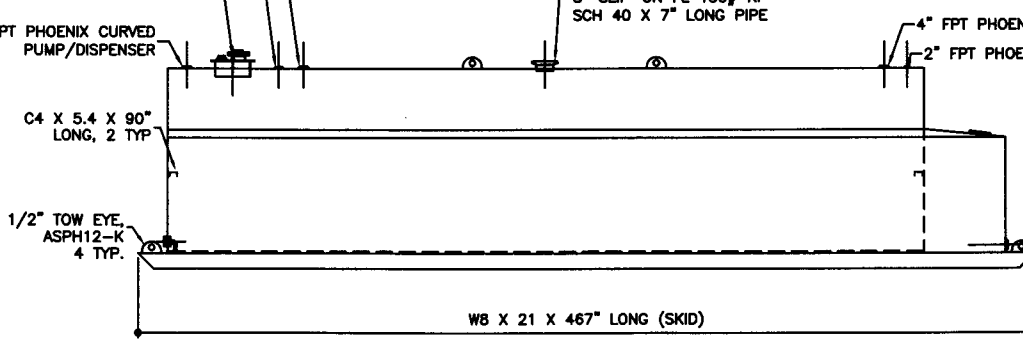

ELEVATION - SIDE VIEW

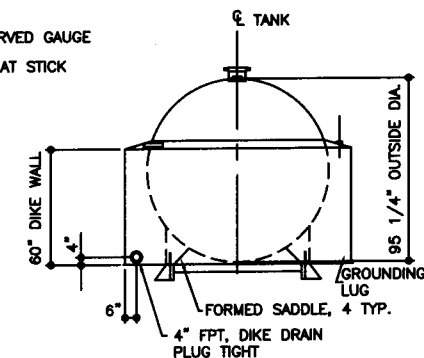

ELEVATION - END VIEW

TOLERANCES	
TANK	
CAPACITY	-0% / +10
OVERALL LENGTH	-0" / +2"
OVERALL WIDTH	-0" / +1"
OVERALL HEIGHT	-1/2" / +1/2"
OTHER DIMENSIONS	-1/4" / +1/4"

UL 142 (BUILT & LABELED)
HOLDDOWNS ARE SEISMIC RATED
DIKE TANK WITH SKID

STEEL: ASTM A36
PRIMARY TANK
SHELL: 2 GAUGE (1/4")
HEAD: 2 GAUGE (1/4")

COATING:
"R" EXTERIOR COATING, ACE 1A
RED SHOP COAT 1-3 MILS

SPECIAL INSTRUCTIONS
PLUG TIGHT
WRENCH PLUG TIGHT WITH PIPE DOPE
ON THREADS AND TESTED LEAK FREE.

STIFFENERS ARE NOT SHOWN IN
ELEVATION VIEWS FOR CLARITY

APPROXIMATE SHIPPING WEIGHT
19,550 LBS.

TANK VENT CAPACITY
428,000



AceDike - 12,000 GALLON

DIKE TANK
FLOOR: 6 GAUGE (3/16")
WALL: 10 GAUGE (9/64")
COWLING: 10 GAUGE (9/64")

"A" EXTERIOR ACE 3A COATING:
SP-6 GRIT BLAST
3A COLOR: #WH01 (WHITE)
1 CT TN-161 EPOXY 3.0-5.0 MILS
1 CT TN-74 URETHANE 2.0-3.0 MILS
TDFT 5.0-8.0 MILS

INTERIOR:
BARE STEEL

JOB ID No. - ACE HOUSE PAPER No. - ENG. FILE No. -
01-01-02 SUPERCEDES 09-01-01

DRW BY -
REV No 1
SHEET 2
OF

NOTE:
1. ALL NOMINAL DIMENSIONS ARE 3"±

BILL OF MATERIAL

ITEM	QTY	NAME	DESCRIPTION	MATL	PART No.	NOTES
1	2	SKID BEAM	W8 X 21 X 467" LONG	A36	-	MOUNT, COAT
2	1	SKID CROSS BRACE	4" SCH 40 PIPE X 68 1/2" LONG	A36	-	MOUNT, COAT
3	2	SKID CROSS BRACE	L4 X 4 X 3/8 X 68 1/2" LONG TOE DOWN COPE ENDS	A36	-	MOUNT, COAT
4	-	SKID CAP	PLATE	A36	-	SEE DTL SHT
5	-	SEISMIC HOLDDOWN	PLATE	A36	-	SEE DTL SHT
6	-	TOW EYE	PLATE	A36	-	SEE DTL SHT

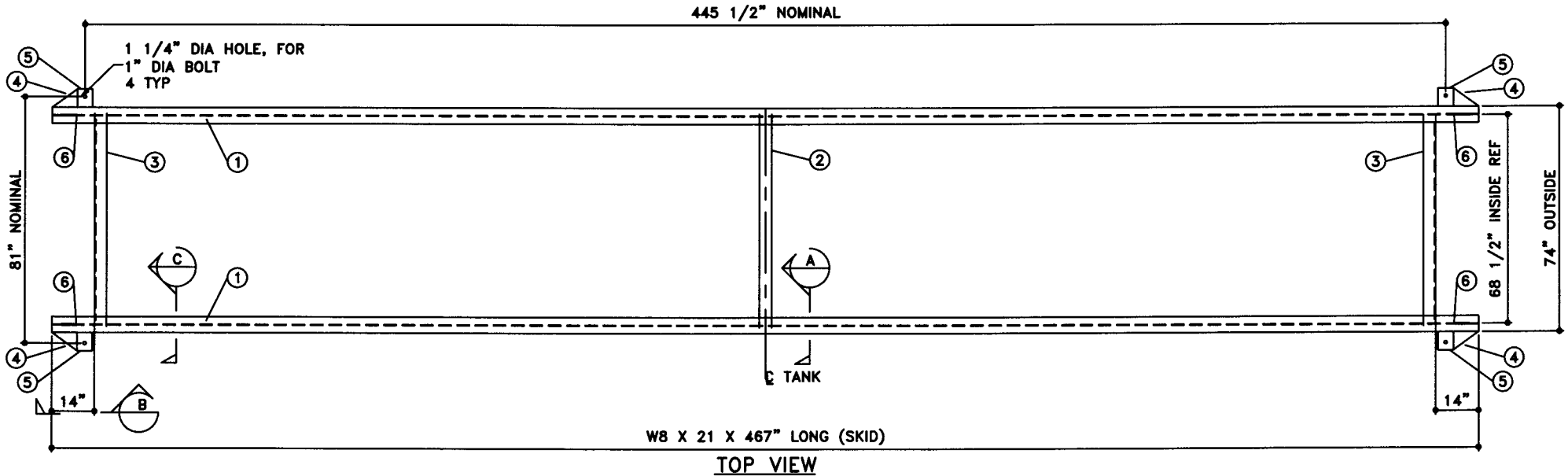

P.O. Box 9039
Seattle, WA 98109-0039

JOB ID No.	-	TOLERANCES
ACE HOUSE PAPER No.	-	SKID
ENGG. FILE No.	-	OVERALL LENGTH -1/4" / +1/4"
		OVERALL WIDTH -1/4" / +1/4"
		OVERALL HEIGHT -1/4" / +1/4"
		OTHER DIMENSIONS -1/8" / +1/8"

QUANTITY	PART NAME	SKID DETAILS
1		
	ACE PART No.	AC12000U2D2
		(1:32)

No.	DRAWING / REVISION	DRAWN BY	CHECKED BY	SHEET
1	1ST SUBMITTAL	-	-	OF
-	-	-	-	
-	-	-	-	
-	-	-	-	

01-01-01 SUPERCEDES