

sti-P<sub>3</sub>®

6,000 GALLON TANK

Part Number AC06000U1P1

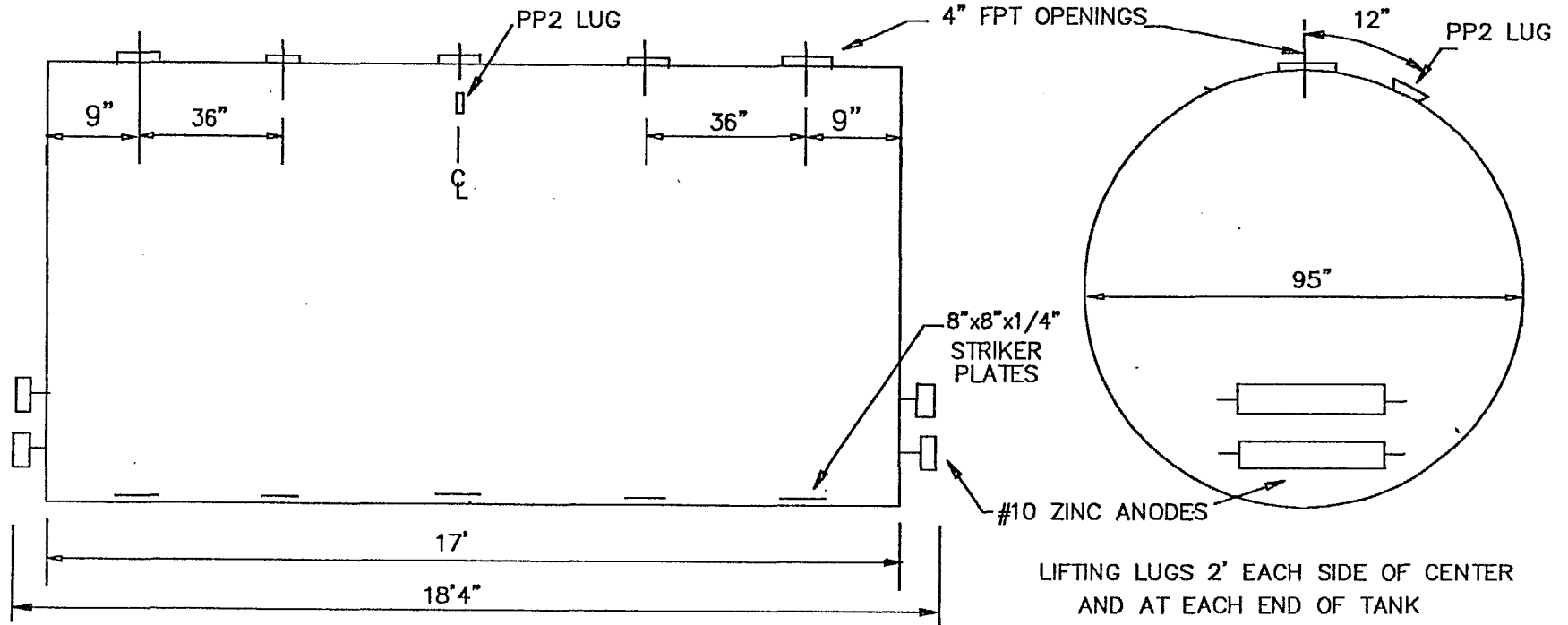

Weight 5,830 lbs. \_\_\_\_\_

Shell Thickness 2 gauge \_\_\_\_\_

Head Thickness 2 gauge \_\_\_\_\_

NOTICE

THIS PRINT AND THE INFORMATION CONTAINED HEREIN IS PROPRIETARY TO ACE TANK & EQUIPMENT CO. AND SHALL NOT BE REPRODUCED OR DISCLOSED IN WHOLE OR IN PART, NOR USED FOR ANY DESIGN OR MANUFACTURING PURPOSES, UNLESS AUTHORIZED IN WRITING BY ACE TANK & EQUIPMENT CO.

 <b>ACE TANK &amp; EQUIPMENT CO.</b> SEATTLE PORTLAND HAYWARD		
FOR: _____		
JOB: _____		
NOT TO SCALE	<input type="radio"/>	REQUIRED
INVOICE # _____	DATE _____	SALESPERSON _____

Openings are female NPT and are bushed to size indicated by using nylon bushings per sti-P<sub>3</sub>® specs.  
 Before coating, tank shall be tested and proved tight under a test pressure between 5 and 7 psi.  
 Exterior coating per sti-P<sub>3</sub>® specs.  
 Tanks shall be built in accordance with UL-58 specifications and shall bear the UL and sti-P<sub>3</sub>® labels.

*Drawing not to scale. Weights & measurements are approximate.*

\_\_\_\_\_  
CUSTOMER APPROVAL SIGNATURE