

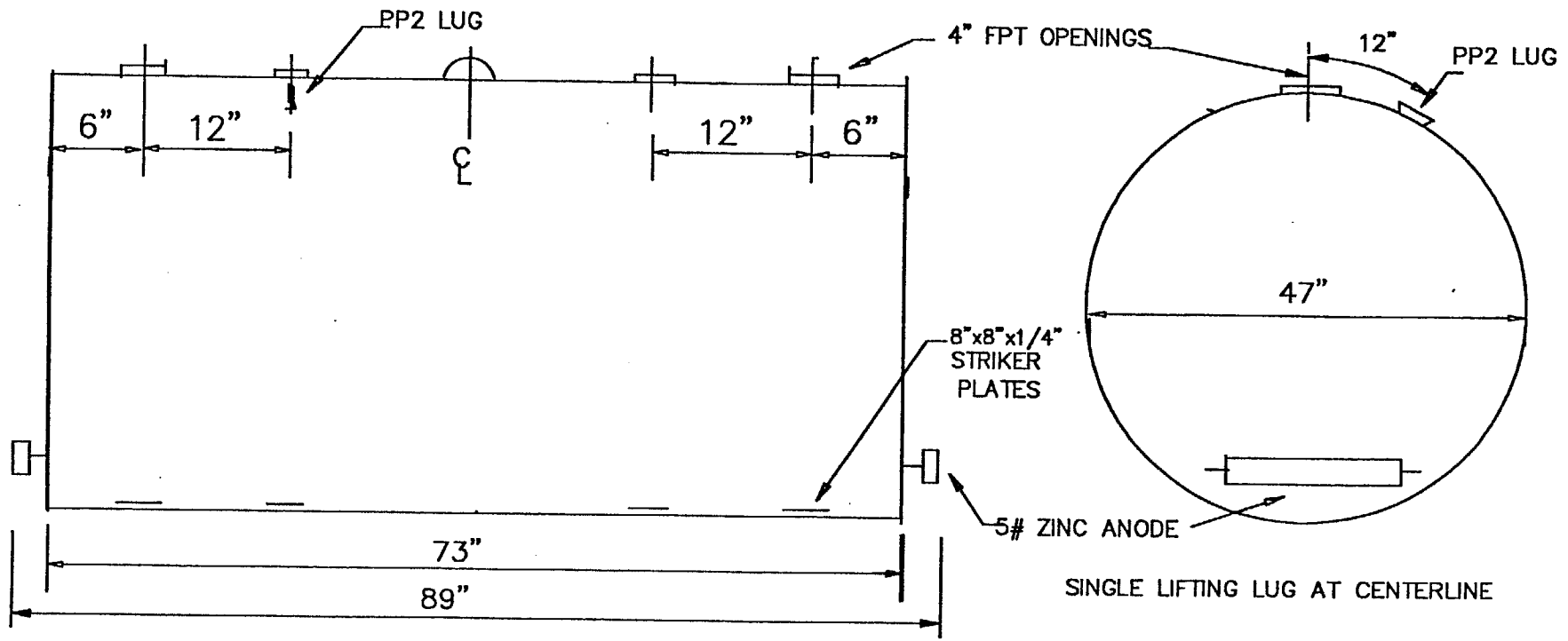

**sti-P<sub>3</sub>** **550 GALLON TANK**  
 Part Number AC00550U1P1



Weight 660 lbs.  
 Shell Thickness 10 gauge  
 Head Thickness 10 gauge

**NOTICE**  
 THIS PRINT AND THE INFORMATION CONTAINED HEREIN IS PROPRIETARY TO ACE TANK & EQUIPMENT CO. AND SHALL NOT BE REPRODUCED OR DISCLOSED IN WHOLE OR IN PART, NOR USED FOR ANY DESIGN OR MANUFACTURING PURPOSES, UNLESS AUTHORIZED IN WRITING BY ACE TANK & EQUIPMENT CO.

Openings are female NPT and are bushed to size indicated by using nylon bushings per sti-P<sub>3</sub>® specifications. Before coating, tank shall be tested and proved tight under a test pressure between 5 and 7 psi. Exterior coating per sti-P<sub>3</sub>® specs. Tanks shall be built in accordance with UL-58 specifications and shall bear the UL and sti-P<sub>3</sub>® labels.

 <b>ACE TANK &amp; EQUIPMENT CO.</b> SEATTLE PORTLAND HAYWARD		
FOR:		
JOB:		
NOT TO SCALE	○	REQUIRED
INVOICE #	DATE	SALESPERSON

Drawing not to scale. Weights & measurements are approximate.

CUSTOMER APPROVAL SIGNATURE