

sti-P₃®

3,000 GALLON TANK

Part Number AC03000U1P1

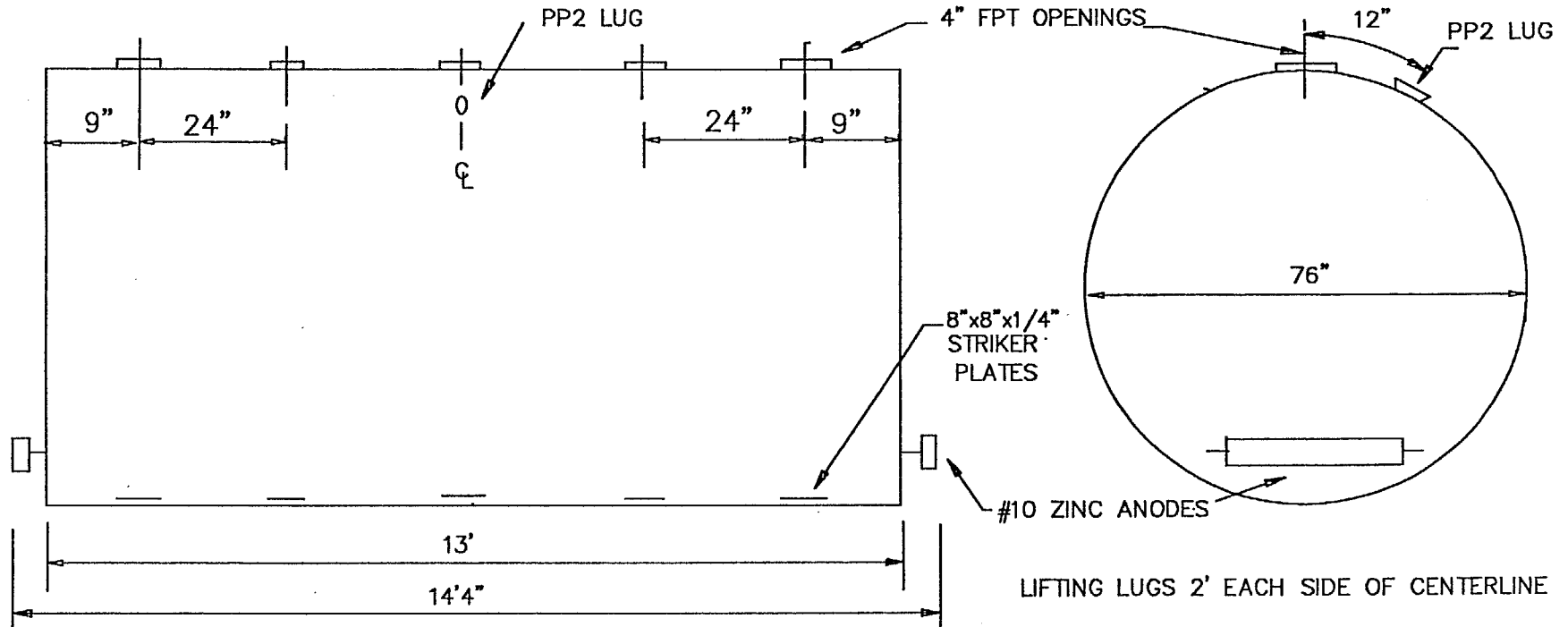

Weight 2,620 lbs. _____

Shell Thickness 6 gauge _____

Head Thickness 6 gauge _____

NOTICE

THIS PRINT AND THE INFORMATION CONTAINED HEREIN IS PROPRIETARY TO ACE TANK & EQUIPMENT CO. AND SHALL NOT BE REPRODUCED OR DISCLOSED IN WHOLE OR IN PART, NOR USED FOR ANY DESIGN OR MANUFACTURING PURPOSES, UNLESS AUTHORIZED IN WRITING BY ACE TANK & EQUIPMENT CO.

 ACE TANK & EQUIPMENT CO. SEATTLE PORTLAND HAYWARD		
FOR: _____		
JOB: _____		
NOT TO SCALE	<input type="checkbox"/> REQUIRED	
INVOICE # _____	DATE _____	SALESPERSON _____

Openings are female NPT and are bushed to size indicated by using nylon bushings per sti-P₃® specs. Before coating, tank shall be tested and proved tight under a test pressure between 5 and 7 psi. Exterior coating per sti-P₃® specs. Tanks shall be built in accordance with UL-58 specifications and shall bear the UL and sti-P₃® labels.

Drawing not to scale. Weights & measurements are approximate.

CUSTOMER APPROVAL SIGNATURE