

TOP VIEW

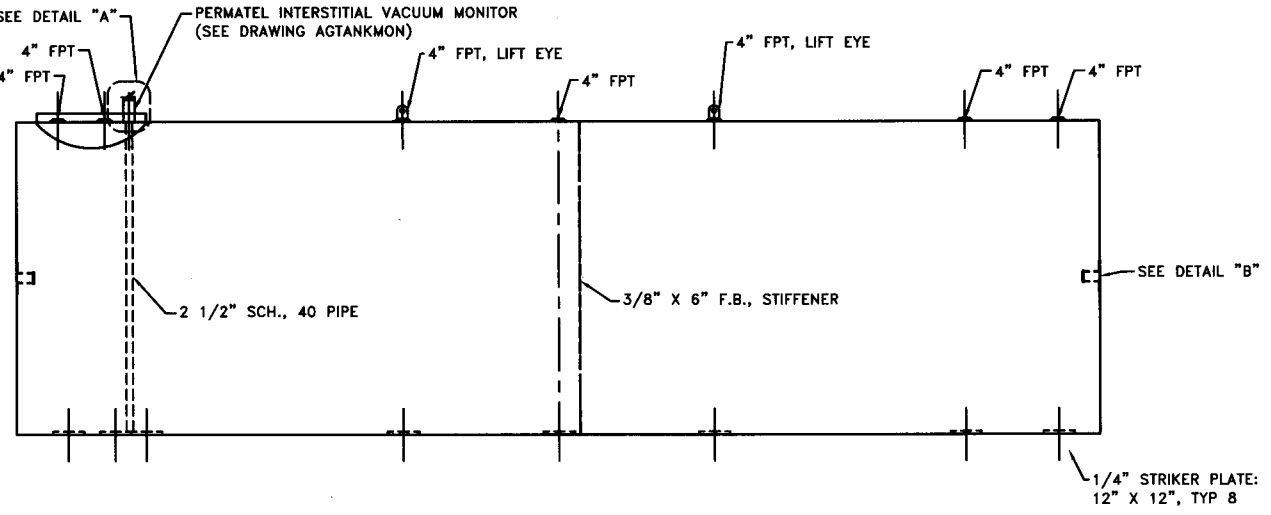

ELEVATION - SIDE VIEW

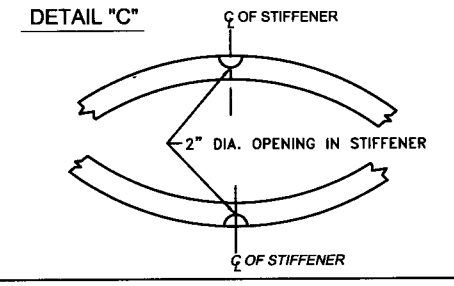
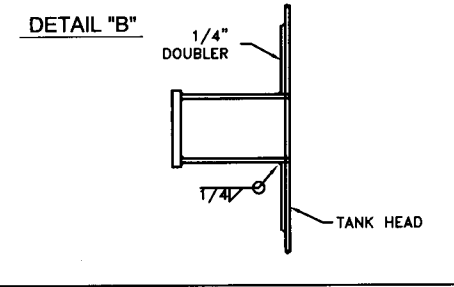
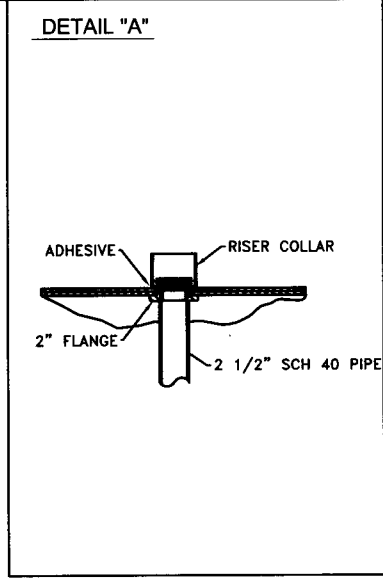
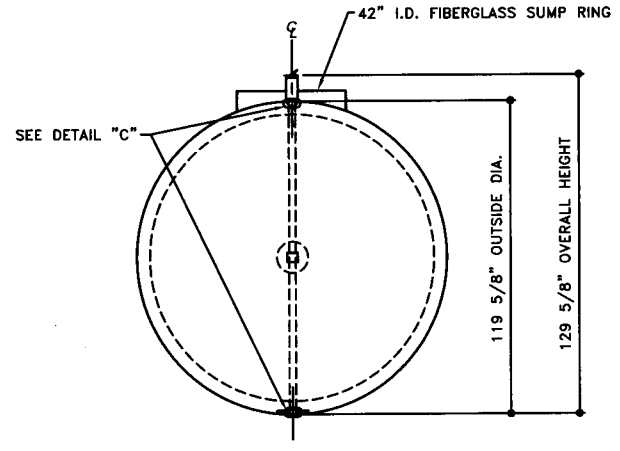

ELEVATION - END VIEW

SERIAL NUMBER AZ0958 AND GREATER

TOLERANCES TANK CAPACITY -0% / +10 OVERALL LENGTH -0' / +2" OVERALL WIDTH -0' / +1" OVERALL HEIGHT -1/2" / +1/2" OTHER DIMENSIONS -1/4" / +1/4" 1-206-281-5000	UL 1746 (BUILT & LABELED) STI, PERMATANK (BUILT & LABELED) DOUBLE WALL PERMATANK	STEEL: ASTM A36 PRIMARY TANK SHELL: 2 ga (1/4") HEAD: 2 ga (1/4")	COATING: EXTERIOR COATING INTERSTITIAL STANDOFF- POLYETHYLENE MESH AND MYLAR SHEETING FRP 100 MIL MIN	SPECIAL INSTRUCTIONS DRY PLUG FITTINGS SCRAPE OUTSIDE SPATTER TANK DIMENSIONS REFER TO STEEL PRIMARY TANK	APPROXIMATE SHIPPING WEIGHT 15,450 LBS.	DRW BY - REV No 1 SHEET 2 OF
	PERMATANK - 20,000 GALLON			INTERIOR: BARE STEEL	ACE HOUSE PAPER No. - ENG. FILE No. - 3-4-99 SUPERCEDES 8-4-97	
ACE PART No. AC20000U2Z3C QTY:	(080497-F:1111ACSHOPIPERMAIU2Z3B2000012-ORTHO.GCD-1.48)					

