

INSTALLATION INSTRUCTIONS

APRIL 2002

1.0 EXCAVATION AND BEDDING

- 1.1 The bottom of the excavation shall be covered with a minimum of 12 inches (305 mm) of bedding, suitably graded and leveled. Bedding and backfill material surrounding the tank, to a width and depth of 12 inches (305 mm) all around the tank, shall be clean material.
- 1.2 Where anchoring by means of a concrete pad, the tank shall not be placed directly on the pad. Bedding material at least 6 inches (152.4 mm) deep must be spread evenly over the dimensions of the pad to separate the tank from the pad.

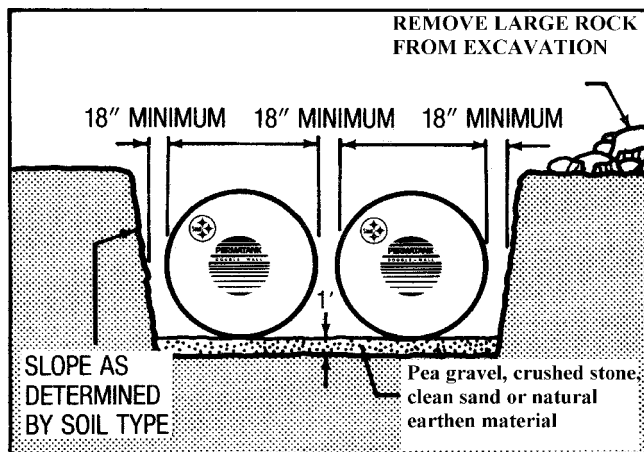

- 1.3 Bedding and backfill material shall consist of homogenous pea gravel, crushed stone, clean sand or natural earthen materials. Crushed stone, clean sand and natural earthen materials shall be capable of passing 100% through a 1/2 inch (13 mm) sieve and no more than 12% by dry weight through a #200 sieve (0.0029 inch (0.0754 mm)). Pea gravel shall be no larger than 3/4-inch (19 mm). The materials shall be free of all foreign materials, such as but not limited to, bricks, metals, concrete and plastics.

- 1.4 The backfill material may be from the tank site if it meets this description, or it may be delivered to the site from another source.
- 1.5 Sand or natural earthen materials used as backfill shall be placed into the excavation in 12-18 inch (305-458 mm) vertical lifts, compacted after each lift, at least 60% up the vertical height of the tank.
- 1.6 If earthen material from the site, or other earthen material, is to be used as bedding or backfill material, a minimum of four 1 cu.ft. samples shall be taken from different locations which are representative of the backfill material and the site.
- 1.7 In a tidal area, the tank "bedding" material shall be crushed stone or pea gravel. Sand and natural earthen material may be used only if measures are taken to prevent washout of material during the design life of the system.

2.0 INTERSTICE VACUUM MONITORING

- 2.1 Assure tightness of tank and secondary containment in accordance with NFPA 30 through verification of vacuum within tank interstice (space in between the steel storage tank and outer fiberglass reinforced plastic (FRP) shell).
- 2.2 The tank is shipped from the factory with a minimum 13 inches Hg (44 kPa) vacuum inside the tank interstice. A vacuum gauge is factory-installed on the tank to monitor the interstice vacuum pressure. Upon delivery of the tank to the site, read and record the vacuum gauge pressure as noted on the Installation Checklist Form. **IMPORTANT:** If the vacuum gauge reading has dropped 5 inches Hg (16.9 kPa) or more below the gauge reading recorded when the tank was delivered, call the tank manufacturer immediately.

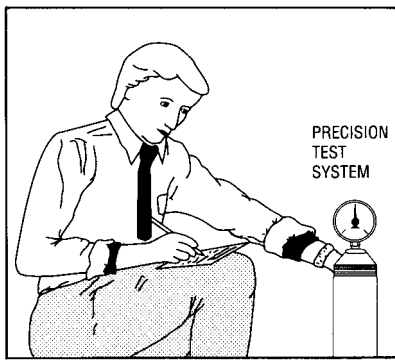

NOTE: Variations in ambient air temperature, atmospheric pressure, exposure to sunlight, etc., can cause slight variations in vacuum gauge readings.

2.3 The vacuum gauge, at a minimum, must be read and its reading recorded in the spaces provided on the Installation Checklist for each of the following tank installation events:

The vacuum gauge should also be read and recorded after the following events:

- At time of tank delivery,
- After backfilling to top of the tank,
- During long-term storage activity,
- At end of storage period before burial,
- After tank placement in excavation.
- After installation of monitor pipe extension to grade level,
- After tank installation has been completed.

3.0 TANK HANDLING

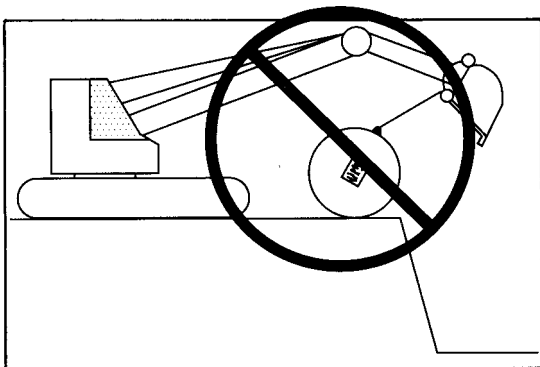

3.1 Equipment to handle the tank shall be of adequate size to lift and lower the tank without dragging and dropping to prevent damage to the tank.

3.2 The tank may arrive with factory installed removable lifting lugs for tank handling. Make sure lifting lugs are secured to the tank and positioned properly, parallel to the longitudinal centerline of the tank, before using.

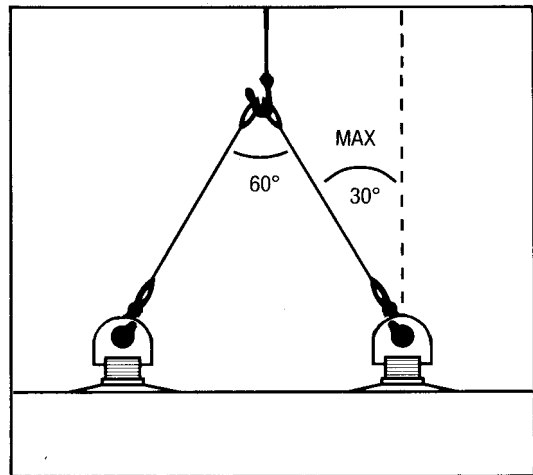

3.3 The tank shall be carefully lifted and lowered into the excavation hole by use of cables or chains of adequate length attached to the lifting lugs provided. A spreader bar shall be used where necessary. Do not use slings, chains or cable around the tank to lift it. Do not roll or drag tank.

3.4 The angle between the vertical and one side of the lifting cable must not exceed a 30 degree included angle. Lift tank only at designated lift points with the lift lugs provided by the tank fabricator. Lift points are designated either by a sticker or by the presence of a lifting device.

3.5 Care shall be taken to prevent impact of the tank with any objects which can damage the tank, including concrete pads, deadman anchors, other tanks, tools and compaction equipment. Use of tank guide lines attached to lift lugs will provide a means of manually controlling tank movement and placement. Do not attach guide lines to the vacuum test station.

3.6 Do not store or place tank on sharp objects or debris. Use non-abrasive cushion-type chocks (i.e., rubber tires) to prevent tank movement during storage. For high wind conditions the tank should be tied down using non-metallic straps.

4.0 TANK STORAGE

- 4.1 If the tank must be temporarily stored, prior to installation, it should be placed in an area away from activity where tank damage could occur.
- 4.2 Factory-installed protective padding material on the tank should remain on the tank until it is ready to be placed in the excavation. Removal of protective padding is optional.
- 4.3 Tank must be installed within one year of delivery from tank manufacturer. If tank is not installed within this time period, contact tank manufacturer to recertify the tank.

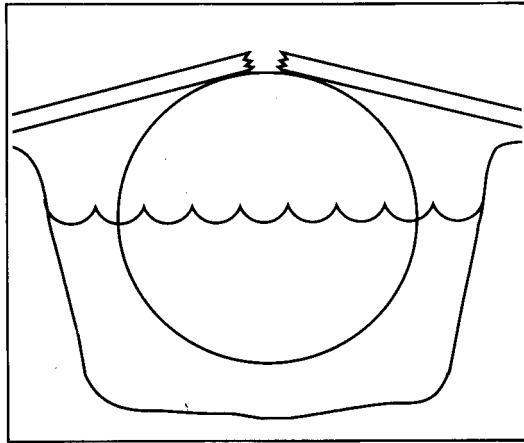

5.0 ANCHORING TANK

- 5.1 High water tables or partially flooded excavation sites exert significant upward buoyant forces on tanks. Buoyant forces are partially resisted by the weight of the tank, the backfill and the pavement on top of the tank. Additional buoyant restraint, when required, is obtained using properly designed hold-down straps in conjunction with concrete hold-down pads or deadman anchors. The use of steel cable and round bar as hold down straps on the tank is prohibited.
- 5.2 If a metallic hold-down strap is used, a pad of inert insulating di-electric material must be used to insulate the hold-down strap from the tank. The separating pad shall be wider than the hold-down straps, which will prevent direct contact between the straps and the tank shell. This pad is not required if the hold-down strap is fabricated from non-conductive material.
- 5.3 The hold-down strap at the end of the tank shall be located at a distance of not

more than $D/4$, where D is the tank diameter. The remaining hold-down straps shall be spaced out approximately equally.

5.4 Ballasting the tank may be necessary. When water is used as the ballast material, it shall only be potable water and shall not remain in the tank longer than 60 days. During construction, adequately vent all tank spaces. If product is used as ballast, proper precautions must be taken to prevent fires, spills, leaks, and other associated accidents. Monitor product level frequently to ensure there has been no unaccounted loss of product.

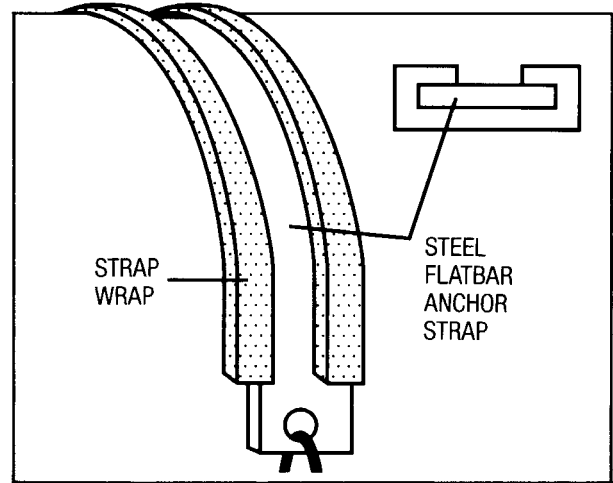

6.0 BACKFILL

- 6.1 Homogeneous backfill similar to bedding material shall be placed carefully around the entire tank to create a uniform homogeneous environment.

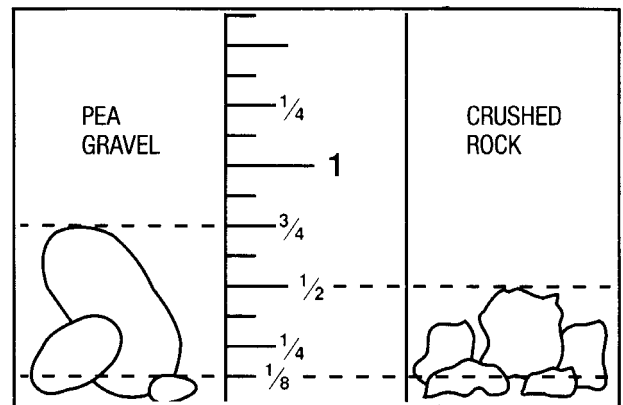

- 6.2 Special care shall be taken when installing backfill along the bottom sides of the tank to ensure that the tank is not damaged and is fully and evenly supported around the bottom quadrant.

- 6.3 The backfill material shall be carefully placed and consolidated along the bottom, under the tank shell, by manually shoveling and tamping.
- 6.4 The initial 2 feet (610 mm) of backfill shall be completed in 12 inch (305 mm) maximum lifts, uniformly placed around the tank. Light hand-operated compaction equipment is recommended for all sand backfills to at least 3 feet (920 mm) above the tank.

7.0 PRECISION TEST SYSTEM (PTS) INSTALLATION

- 7.1 The Precision Test System (PTS) is factory-installed on top of the tank and provides a means to monitor the vacuum pressure inside the interstitial space between the steel tank and FRP shell.
- 7.2 The PTS consists of a vacuum gauge, manual shutoff and hose assembly housed and protected by a factory-installed piece of 4 inch (102 mm) PVC pipe.
- 7.3 To bring the PTS to grade level, carefully remove and discard the short length of factory-installed protective PVC pipe.

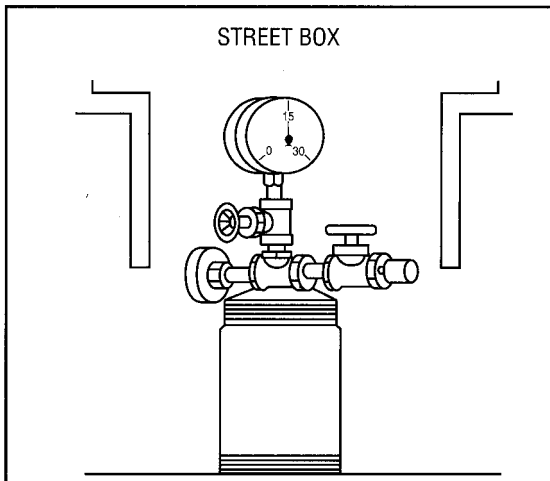

- 7.4 Determine the height dimension from top of tank to finished grade, then deduct 10 inches (254 mm) (depth of street box) and cut the 60 inch (1.52 m) section of PVC pipe supplied to this length.
- 7.5 Carefully stretch the hose and wire to the length of the cut PVC pipe, then carefully slide the PVC pipe completely over the vacuum gauge hose and wire. Slide the pipe down over the tank base collar and glue.

8.0 TANK PIPING CONNECTION TEST

- 8.1 As the PTS already verifies tank tightness, one final test is still necessary to assure proper installation of the pipe connections to the tank fittings. Remove all factory-installed thread protectors.
- 8.2 Pressure applied to the internal steel tank shall be 3-5 psig (20.7-34.5 kPa). Shut-off the compressed air source to the system. A soap solution shall be applied around all tank piping connections while test is being performed. Bubbles and/or foam indicates leakage.
WARNING: DO NOT PRESSURIZE THE INTERSTITIAL SPACE.
- 8.3 After passing leak testing, release tank air pressure by allowing it to escape slowly through the connection used to pressurize the tank.

9.0 FINAL BACKFILL

- 9.1 Homogenous backfill shall be deposited carefully around the tank up to top of the tank and to a depth of at least 1 foot (305 mm) over the tank to avoid damage to laminate, especially where tamping is required. (See NFPA 30 or UFC and state or local codes for minimum depth of cover required prior to allowing vehicular traffic over the tanks.)

10.0 OPERATING LIMITATIONS

- Operation of the tank above 120°F (49°C) requires the use of specific components and materials. The tank manufacturer must be notified, prior to tank use, of the owner's intent to operate this tank above 120°F (49°C) so that proper components and materials can be incorporated.
- 10.1 When the product stored is heated, the temperature inside the tank shall be constantly monitored to assure the maximum allowable temperature of 120°F (49°C) is not exceeded.

11.0 MAINTENANCE

- 11.1 The primary tank shall be inspected monthly for the presence of water. Inspection shall take place at the lowest possible points inside the primary tank. Remove any water found. Water and sediment in fuel can cause plugging of filters. Also, bacterial growth, originating

from the fuel, can cause filters to plug and corrosion of tanks and lines. For procedures on how to check for the presence of water and removal of water, refer to API recommended Practice 1621, Appendix D and API Standard 2610. Another source of information is a report by the US Department of Energy, Brookhaven National Laboratory BNL 48406, provides information on methods to test for and remove water, test for bacterial presence in fuel tank cleaning and fuel additives.

Disclaimer

These instructions are intended only as an aid to tank installers who are knowledgeable and experienced in underground tank installation. Compliance herewith does not necessarily meet the requirements of applicable federal, state and local laws, regulations and ordinances concerning tank installation. STI makes no warranties, express or implied, including but not limited to any implied warranties of merchantability or fitness for a particular purpose, as a result of these installation instructions.

Permatank® Installation Final Precision Test

1. The vacuum for the test shall be a minimum of 13-inches of Hg at the start.
2. Test period shall be 12 hours for 10,000 gallon and smaller tanks and 24 hours for larger tanks.
3. Vacuum decreases of less than 5-inches of Hg during test period indicate that the tank is tight. Record vacuum change, if any, in the space provided on Installation Checklist.
4. A vacuum decrease of more than 5-inches of Hg during test period requires further investigation.
5. If further investigation is required, the tank manufacturer shall be contacted. After investigation is complete, this test shall be repeated.
6. The test procedure meets Environmental Protection Agency (EPA) requirements for tightness testing of underground storage tanks for empty tanks in dry excavations.

Interstitial Tightness Testing Method: Permatank®

Version: Installation Test

Certification of Results

I certify that the interstitial monitor was installed and operated according to the vendor's instructions. I also certify that the evaluation was performed using methods which meet the requirements of the Alternative EPA test procedures as they are applied to interstitial monitors and that the results presented above are those obtained during evaluation.

H. Kendall Wilcox, president

(printed name)

H. Kendall Wilcox

(signature)

March 25, 1993

(date)

Ken Wilcox Associates, Inc.

(organization performing evaluation)

Blue Springs, MO 64015

(city, state, zip)

(816) 229-0860

(phone number)



R923-01

INSTALLATION CHECKLIST

MAY 2001

This checklist must be completed by the installation contractor and returned to the tank owner.

Owner of Tank: _____
 Location of Tank: _____

 Installation Company: _____

Permatank® Label No. _____
 Delivery Date: _____
 Tank Capacity: _____ gallons(l)
 Diameter: _____ feet(m); Length: _____ feet (m)
 Product to be stored: _____

● HANDLING

- Lift equipment used _____
- Lifting capacity _____ Lbs.(Kg)
- Type of chocks used if tank was stored _____
- Describe any damage observed _____
- _____
- **Action taken** _____

● EXCAVATION

- Length _____ Width _____ Depth _____
- Burial depth top of tank to grade _____ inches(mm)
- 18 inches (457 mm) minimum around each tank _____
 (Check when complete)
- Burial depths meet minimum code requirements
 (reference NFPA 30, UFC)

NOTE: Check with tank manufacturer if burial depth exceeds 5 feet.

● ANCHORING USED (Check One)

- Concrete Pad _____ Deadman _____ OR
- Soil and pavement overburden will hold do _____
 (reference PEI/RP 100-90)
- Number of hold-down straps _____ Width _____ inches(mm)
- Protective pads used under straps _____
- Protective pad at least 2 inches (50 mm) wider than width of hold-down strap, or wrap around type pad used _____
- 1 foot (304 mm) of backfill material under tank _____ OR
- 6 inch (152 mm) separation when concrete pad is used _____

● BACKFILL

- Material: clean sand _____ pea gravel _____ #8 stone _____
- Depth of homogenous material beneath tank _____ inches
- Backfill has been placed to ensure full support along the tank's bottom quadrant _____

● TANK PIPING CONNECTION TEST

- Pipe fittings air-tested at 5 psig (34.5 kPa) while applying soap solution onto fittings to check for leaks _____

● INTERSTICE PRECISION TEST SYSTEM GAUGE READINGS

- AT:** _____ **Date:** _____
- Tank Delivery _____ inches (kPa) of Hg _____
 Driver signature _____
 Installer signature _____ **Date:** _____
 - after backfill to tank top _____ inches (kPa) of Hg _____
 - after installation if completed _____ inches (kPa) of Hg _____
 - Other readings obtained _____ inches (kPa) of Hg _____

 (Signature of Installing Foreman or Project Engineer)

● PIPING USED (Check all that apply)

- Non-conductive _____ Metallic _____
- Secondary containment used _____ Flexible _____
- Was monitoring pipe extension installed?
 Yes _____ No _____

 (Signature of Installing Foreman or Project Engineer)

● COMMENTS:

TANK OWNER'S MAILING ADDRESS:

Street _____
 City _____
 State _____ Zip _____ Telephone _____

570 Oakwood Road
 Lake Zurich IL 60047
 Phone: 847-438-8265



Note: This checklist includes certain key steps in the proper installation of a double wall steel underground storage tank with FRP secondary containment and is intended only as an aid to tank installers who are knowledgeable and experienced in underground tank installation. Compliance herewith does not necessarily meet the requirements of all applicable federal, state and local laws, regulations and ordinances concerning tank installation. **TANK OWNER - A COPY OF THIS CHECKLIST SHOULD BE RETURNED TO YOU BY THE INSTALLER FOR RETENTION WITH YOUR PERMANENT RECORDS.**