

4" FPT ACFGPIPE5X6, AUXILARY STAGE II, VAPOR RECOVERY  
 3" FPT ACFGPIPE4X9, VENT PRIMARY, STAGE I VAPOR RECOVERY  
 TOP VIEW

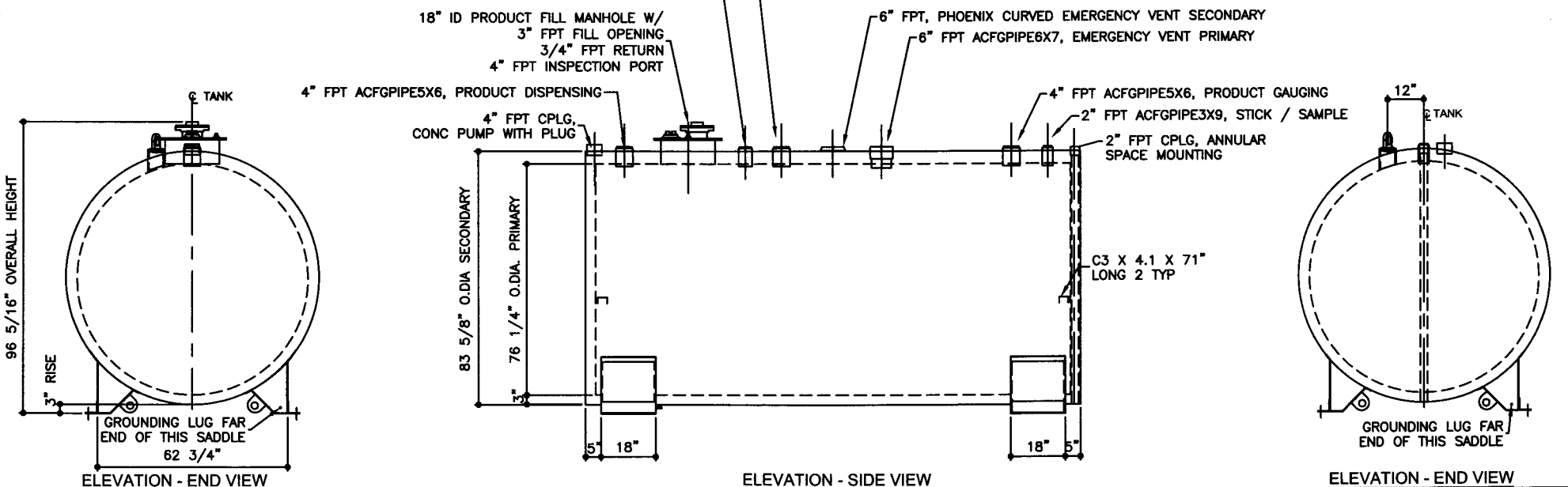

ELEVATION - SIDE VIEW

ELEVATION - END VIEW

TOLERANCES	
TANK	
CAPACITY	-0% / +10
OVERALL LENGTH	-0" / +2"
OVERALL WIDTH	-0" / +1"
OVERALL HEIGHT	-1/2" / +1/2"
OTHER DIMENSIONS	-1/4" / +1/4"

UL 2085 (BUILT & LABELED)  
 UL 142 (BUILT & LABELED)  
 STI-F941 (BUILT & LABELED)  
 HOLDDOWNS ARE SEISMIC RATED  
 DOUBLE WALL WITH 3" INSULATION  
 CYLINDRICAL FIREGUARD WITH SUPPORTS

STEEL: ASTM A36  
 PRIMARY TANK  
 SHELL: 6 GAUGE (3/16")  
 HEAD: 6 GAUGE (3/16")

COATING:  
 EXTERIOR ACE 3A COATING:  
 SP-6 GRIT BLAST  
 3A COLOR: #WH01 (WHITE)  
 1 CT TN-161 EPOXY 3.0-5.0 MILS  
 1 CT TN-74 URETHANE 2.0-3.0 MILS  
 TDFT 5.0-8.0 MILS

SPECIAL INSTRUCTIONS  
 FILL ANNULAR SPACE WITH  
 PORTLAND CEMENT / PERLITE,  
 CEMENT GRADE MIX.  
 LEAVE 1" AIR GAP BETWEEN  
 PERLITE & SECONDARY TANK  
 INTERSTITIAL SPACE: 103 CUBIC FEET

APPROXIMATE SHIPPING WEIGHT  
 10,725 LBS.  
 7,425 LBS. (WITHOUT CEMENT)  
 TANK VENT CAPACITY  
 239,000 PRIMARY  
 265,000 SECONDARY

DRW BY	-
REV No	1
SHEET	2
OF	-



**FIREGUARD - 3,000 GALLON**

ACE PART No.	AC03000U2G1	QTY: 1
(F:111)ACSHOP\FIREGUARD\U2G1-3003000U2-ORTHO.GCD-1:32)		

SECONDARY TANK  
 SHELL: 6 GAUGE (3/16")  
 HEAD: 0 GAUGE (5/16")

INTERIOR:  
 BARE STEEL

JOB ID No.	ACE HOUSE PAPER No.	ENG. FILE No.
-	-	-
01-01-02 SUPERCEDES 10-01-01		

# BILL OF MATERIAL

ITEM	QTY	NAME	DESCRIPTION	MATL	PART No.	NOTES
1	4	HOLD DOWN	L4 X 4 X 1/4 X 18" LONG	A36	-	-
2	-	SADDLE	-	-	-	SEE DETAIL SHT

**NOTE:**

1. ALL NOMINAL DIMENSIONS ARE 2"±

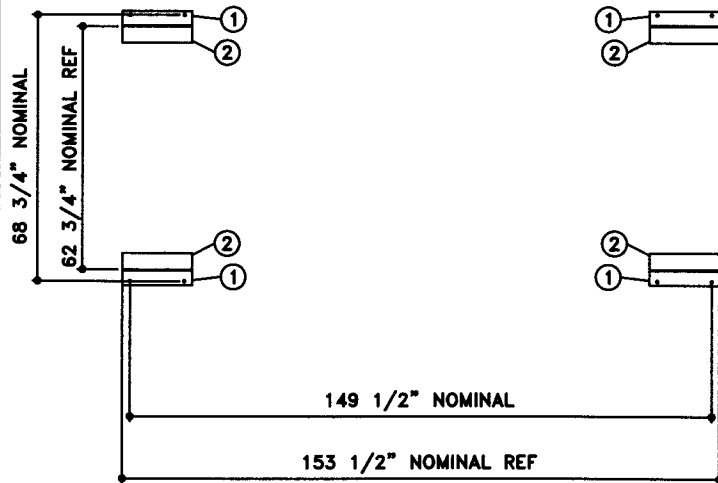

**HOLDDOWN - TOP VIEW**

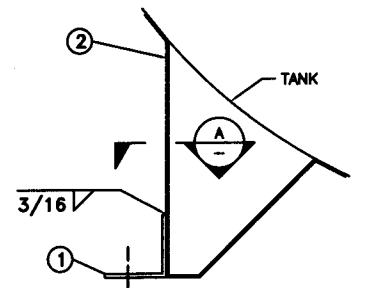
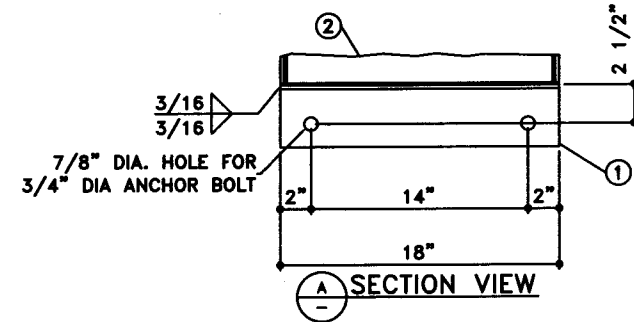

**ELEVATION - END VIEW  
SEISMIC HOLD DOWN**

**Acetank & Equipment**  
 HOLDDOWN - TOP VIEW  
 P.O. Box 9039  
 Seattle, WA 98109-0039

TOLERANCES	
SEISMIC HOLD DOWN	
OVERALL LENGTH	-1/16" / +1/16"
OVERALL WIDTH	-1/16" / +1/16"
OVERALL HEIGHT	-1/16" / +1/16"
OTHER DIMENSIONS	-1/16" / +1/16"

QUANTITY	PART NAME
1	SEISMIC HOLD DOWN - DETAIL
	ACE PART No. AC03000U2G1
	(1:08)

No.	DRAWING / REVISION	DRAWN BY	CHECKED BY	SHEET
1	1ST SUBMITTAL	-	-	OF
-	-	-	-	-
-	-	-	-	-
-	-	-	-	-
01-01-01 SUPERCEDES				