

TOP VIEW

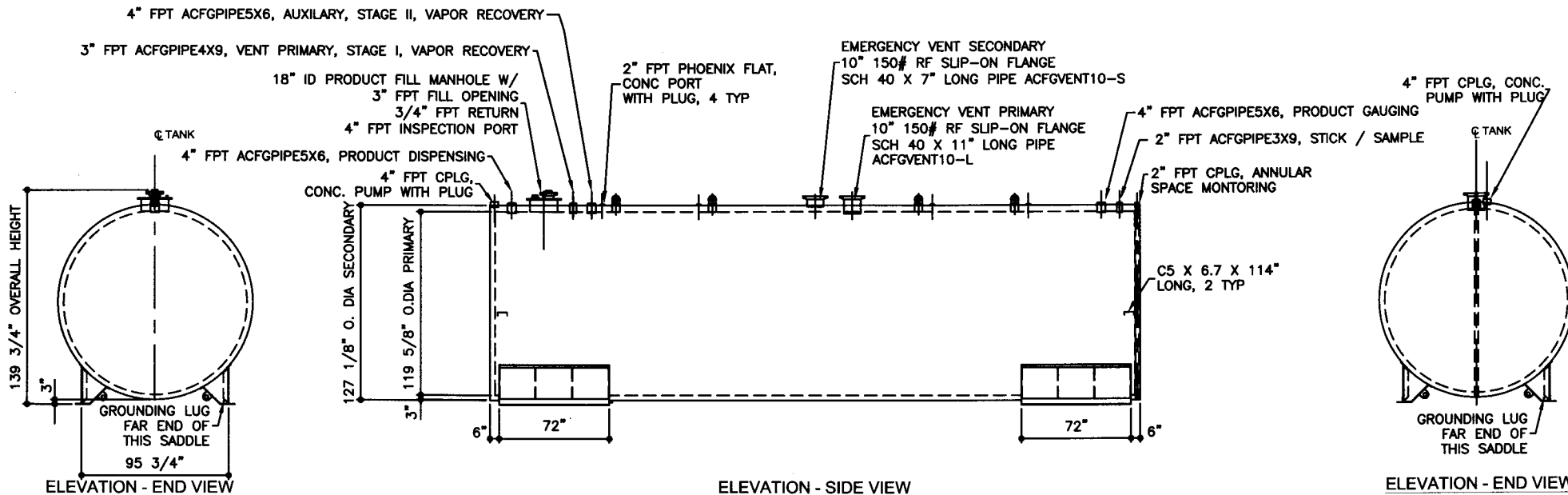

ELEVATION - END VIEW

ELEVATION - SIDE VIEW

ELEVATION - END VIEW

TOLERANCES TANK CAPACITY -0% / +10 OVERALL LENGTH -0" / +2" OVERALL WIDTH -0" / +1" OVERALL HEIGHT -1/2" / +1/2" OTHER DIMENSIONS -1/4" / +1/4"		UL 2085 (BUILT & LABELED) UL 142 (BUILT & LABELED) STI-F941 (BUILT & LABELED) HOLDDOWNS ARE SEISMIC RATED DOUBLE WALL WITH 3" INSULATION CYLINDRICAL FIREGUARD WITH SUPPORTS		STEEL: ASTM A36 PRIMARY TANK SHELL: 2 GAUGE (1/4") HEAD: 2 GAUGE (1/4")		COATING: EXTERIOR ACE 3A COATING: SP-6 GRIT BLAST 3A COLOR: #WH01 (WHITE) 1 CT TN-161 EPOXY 3.0-5.0 MILS 1 CT TN-74 URETHANE 2.0-3.0 MILS TDFT 5.0-8.0 MILS		SPECIAL INSTRUCTIONS FILL ANNULAR SPACE WITH PORTLAND CEMENT / PERLITE, CEMENT GRADE MIX. LEAVE 1" AIR GAP BETWEEN PERLITE & SECONDARY TANK INTERSTITIAL SPACE: 395 CUBIC FEET		APPROXIMATE SHIPPING WEIGHT 46,550 LBS. 33,925 LBS. (WITHOUT CEMENT) TANK VENT CAPACITY 524,000 PRIMARY 524,000 SECONDARY		DRW BY - REV No 1 SHEET 2 OF -
FIREGUARD - 20,000 GALLON ACE PART No. AC20000U2G1 QTY: 1 (F:111ACSHOPIFIREGARDIU2G1-312000012-ORTHO.GCD-1.64)		SECONDARY TANK SHELL: 2 GAUGE (1/4") HEAD: 0 GAUGE (5/16")		INTERIOR: BARE STEEL		INTERSTITIAL SPACE: 395 CUBIC FEET		JOB ID No. - ACE HOUSE PAPER No. - ENG. FILE No. - 01-01-02 SUPERCEDES 10-01-01				



BILL OF MATERIAL

ITEM	QTY	NAME	DESCRIPTION	MATL	PART No.	NOTES
1	4	HOLD DOWN	L4 X 4 X 1/4 X 72" LONG	A36	-	-
2	-	SADDLE	-	-	-	SEE DETAIL SHT

NOTE:
1. ALL NOMINAL DIMENSIONS ARE 3"±

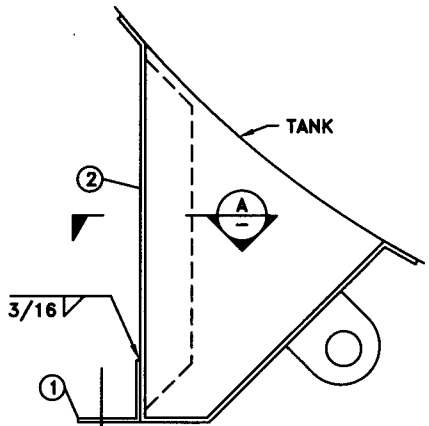

ELEVATION - END VIEW
SEISMIC HOLD DOWN

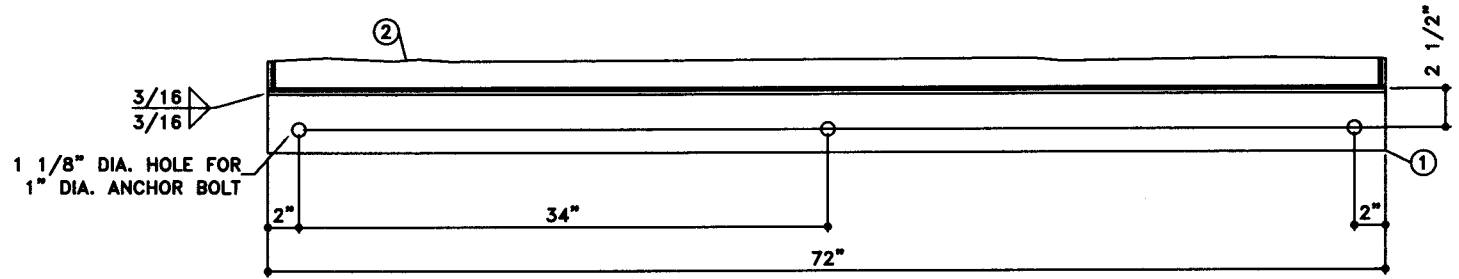

SECTION VIEW

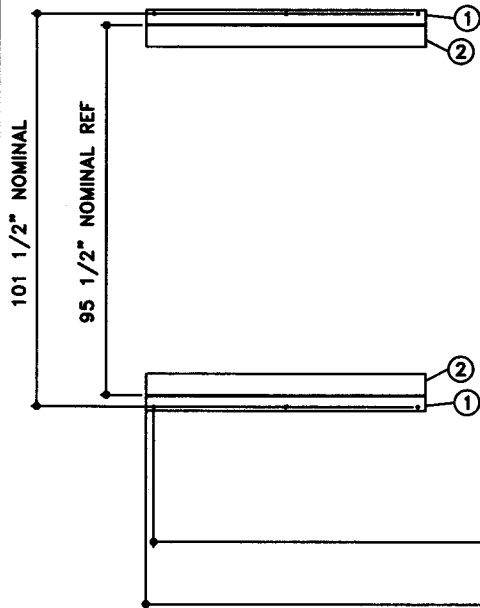

HOLDDOWN - TOP VIEW

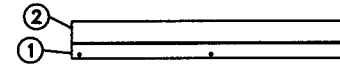
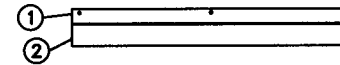

P.O. Box 9039
Seattle, WA 98109-0039

JOB ID No.	TOLERANCES
-	SEISMIC HOLD DOWN
ACE HOUSE PAPER No.	OVERALL LENGTH -1/16" / +1/16"
-	OVERALL WIDTH -1/16" / +1/16"
ENGG. FILE No.	OVERALL HEIGHT -1/16" / +1/16"
-	OTHER DIMENSIONS -1/16" / +1/16"

QUANTITY	PART NAME
1	SEISMIC HOLD DOWN - DETAIL
	ACE PART No. AC20000U2G1
	(1:08)

No.	DRAWING / REVISION	DRAWN BY	CHECKED BY	SHEET
1	1ST SUBMITTAL	-	-	-
-	-	-	-	-
-	-	-	-	-
-	-	-	-	-
-	-	-	-	-
01-01-01 SUPERCEDES				OF