

TOP VIEW

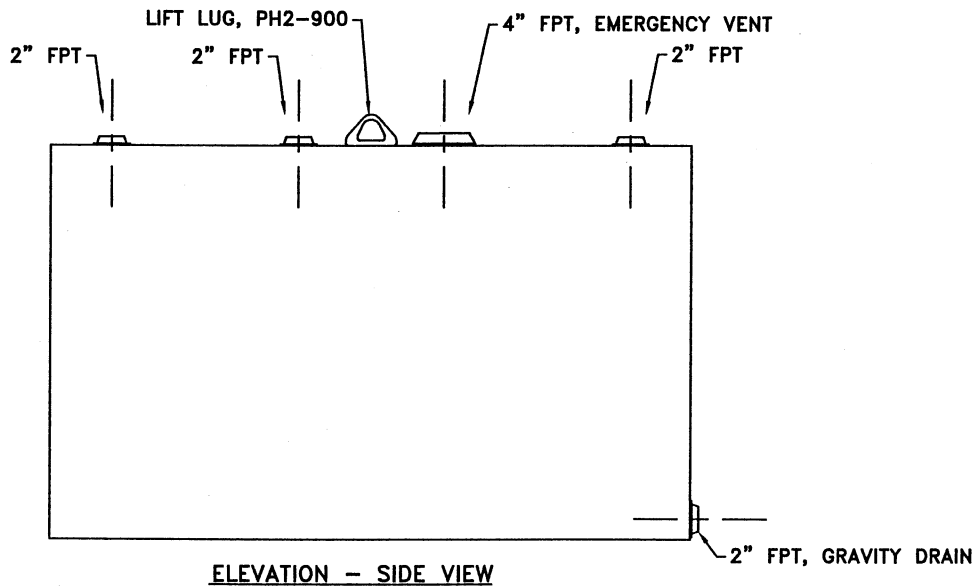

ELEVATION - SIDE VIEW

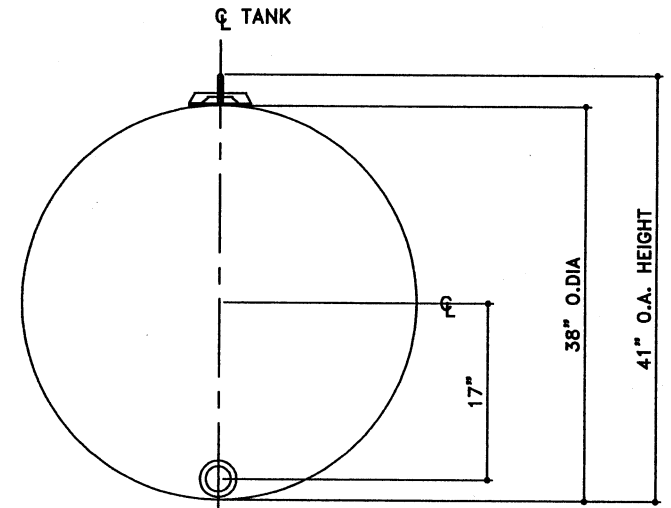

ELEVATION - END VIEW

**TOLERANCES**

TANK	
CAPACITY	-0% / +10
OVERALL LENGTH	-0' / +2'
OVERALL WIDTH	-0' / +1"
OVERALL HEIGHT	-1/2' / +1/2'
OTHER DIMENSIONS	-1/4" / +1/4"

UL 142 (BUILT & LABELED)  
SINGLE WALL TANK  
ABOVEGROUND TANK

STEEL: ASTM A36  
TANK  
SHELL: 12 GA (7/64")  
HEAD: 12 GA (7/64")

COATING:  
"R" EXTERIOR COATING, ACE 1A  
RED SHOP COAT 1-3 MILS

SPECIAL INSTRUCTIONS  
PLUG TIGHT  
WRENCH PLUG TIGHT WITH PIPE  
DOPE ON THREADS AND TESTED  
LEAK FREE.

APPROXIMATE SHIPPING WEIGHT:  
315 LBS.

TANK VENT CAPACITY  
52,700

DRW BY

-

REV No

1

SHEET

2

OF

1

2

OF

1

**Farm Tank - 300 GALLON**

ACE PART No. AC00300U1A1

QTY:

(1:12)

"A" EXTERIOR COATING, ACE 3A  
SP-6 SANDBLAST  
TNEC 181 (3-5 MILS.)  
TNEC 74 (2-3 MILS.)  
TOTAL DFT: 5-8 MILS.  
3A COLOR: WHITE (#WH01)

INTERIOR:  
BARE STEEL

JOB ID No. ACE HOUSE PAPER No. ENG. FILE No.

- - -

8-28-97 SUPERCEDES 00-00-00



COPYRIGHT 1997 ACE TANK & EQUIPMENT