

TOP VIEW

4" FPT CPLG SPARE/STAGE 2 VAPOR RECOVERY  
 3" FPT CPLG NORMAL VENT/STAGE 1 VAPOR RECOVERY

18" ID PRODUCT FILL MANHOLE  
 3" FPT FULL CPLG LOWFILL OPENING  
 3/4" FPT FULL CPLG RETURN  
 4" FPT PHOENIX FLAT INSPECTION OPENING

PRIMARY EMERGENCY VENT  
 10" SLIP-ON FL 150# RF  
 SCH 40 X 7" LONG PIPE

SECONDARY EMERGENCY VENT  
 10" SLIP-ON FL 150# RF  
 SCH 40 X 7" LONG PIPE

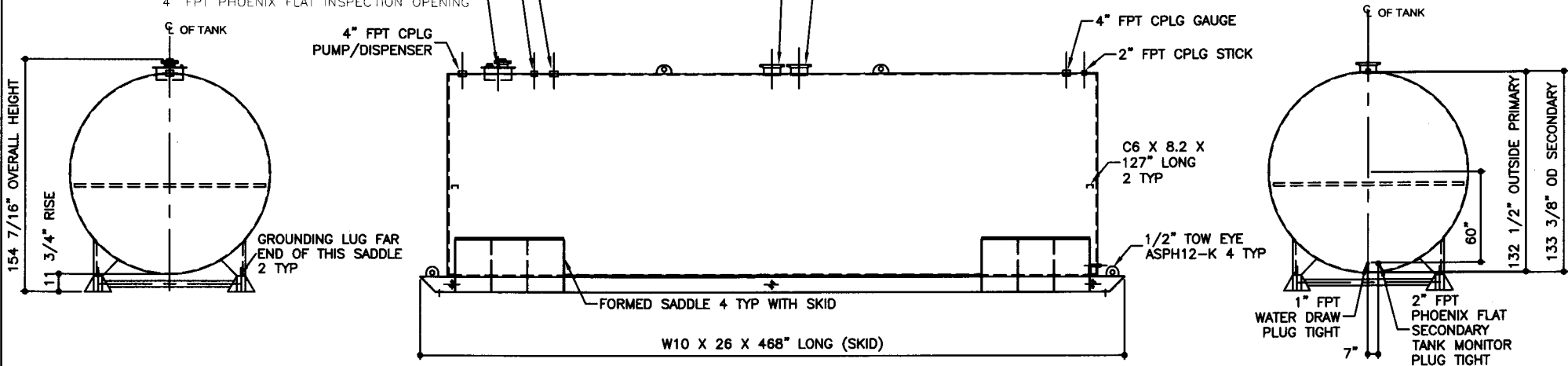

ELEVATION - END VIEW

ELEVATION - SIDE VIEW

ELEVATION - END VIEW

TOLERANCES		UL 142 (BUILT & LABELED) HOLDDOWNS ARE SEISMIC RATED DOUBLE WALL SKID TANK	STEEL: ASTM A36 PRIMARY TANK SHELL: 2 GAUGE (1/4") HEAD: 2 GAUGE (1/4")	COATING: "R" EXTERIOR COATING, ACE 1A RED SHOP COAT 1-3 MILS  "A" EXTERIOR ACE 3A COATING: SP-6 GRIT BLAST 3A COLOR: #WH01 (WHITE) 1 CT TN-161 EPOXY 3.0-5.0 MILS 1 CT TN-74 URETHANE 2.0-3.0 MILS TDFT 5.0-8.0 MILS	SPECIAL INSTRUCTIONS PLUG TIGHT WRENCH PLUG TIGHT WITH PIPE DOPE ON THREADS AND TESTED LEAK FREE.  STIFFENERS ARE NOT SHOWN IN ELEVATION VIEWS FOR CLARITY	APPROXIMATE SHIPPING WEIGHT 33,300 LBS.  TANK VENT CAPACITY 557,000 PRIMARY TANK  557,000 SECONDARY TANK	DRW BY - REV No 1  SHEET 2  OF OF
CAPACITY	-0% / +10						
OVERALL LENGTH	-0" / +2"	AceSkidLite II - 25,000 GALLON	QTY: 1	1206-281-5000			
OVERALL WIDTH	-0" / +1"	ACE PART No. AC25000U2K4					
OVERALL HEIGHT	-1/2" / +1/2"	(F:111ACSHOPISKIDU2K425000)2-ORTH.GCD-1:64					
OTHER DIMENSIONS	-1/4" / +1/4"						



NOTE:  
1. ALL NOMINAL DIMENSIONS ARE 3"±

### BILL OF MATERIAL

ITEM	QTY	NAME	DESCRIPTION	MATL	PART No.	NOTES
1	2	SKID	W10 X 26 X 468" LONG	A36	-	-
2	3	SKID CROSS BRACE	4" SCH. 40 PIPE X 95 1/4" LONG	A36	-	-
3	-	TOW EYE	TYPE 2 LIFT LUG	A36	-	SEE DTL SHIT
4	-	HOLDDOWN	-	A36	-	SEE DTL SHIT
5	-	SKID CAP	-	A36	-	SEE DTL SHIT

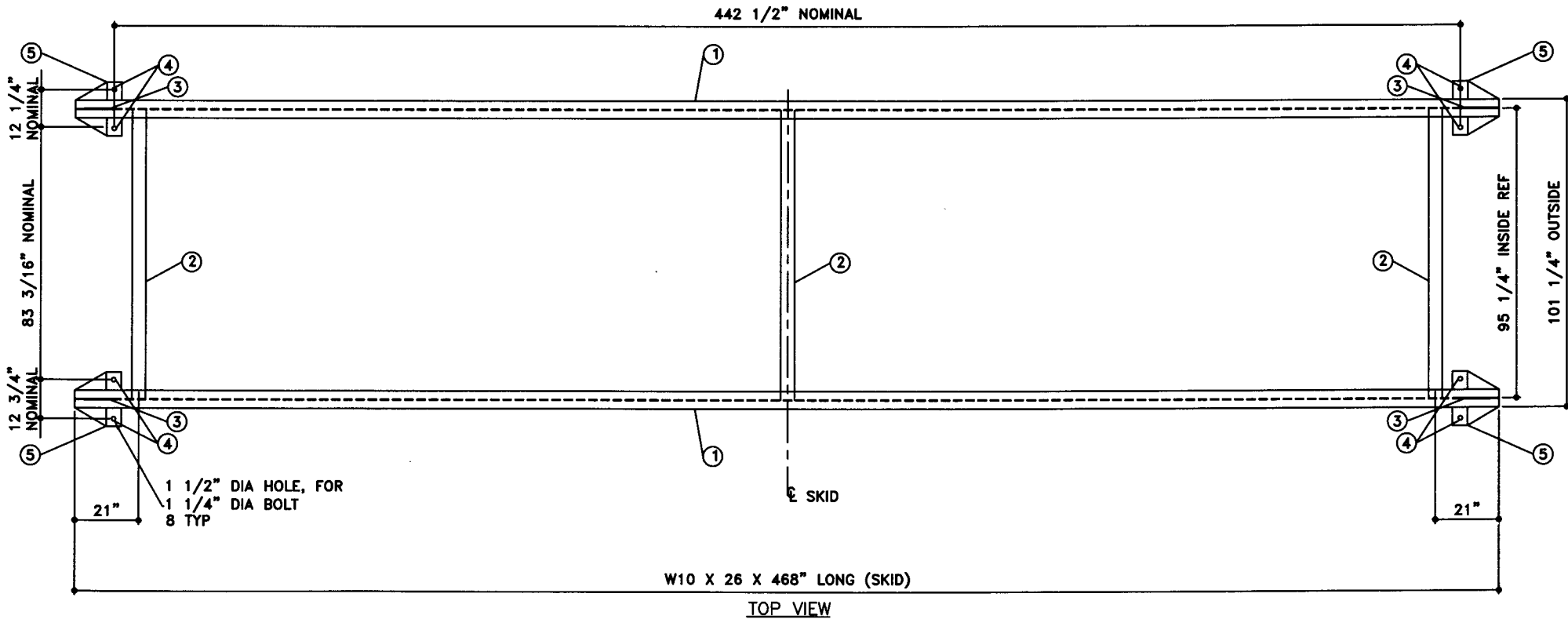

JOB ID No.	TOLERANCES
-	SKID
ACE HOUSE PAPER No.	OVERALL LENGTH -1/4" / +1/4"
ENGG. FILE No.	OVERALL WIDTH -1/4" / +1/4"
-	OVERALL HEIGHT -1/4" / +1/4"
-	OTHER DIMENSIONS -1/8" / +1/8"

QUANTITY	PART NAME
1	SKID DETAILS
-	-
-	ACE PART No. AC25000U2K4
-	(1:32)

No.	DRAWING / REVISION	DRWN BY	CHECKED BY	SHEET
1	1ST SUBMITTAL	-	-	OF
-	-	-	-	-
-	-	-	-	-
-	-	-	-	-
01-01-01 SUPERCEDES				