

TOP VIEW

- 6" FPT PHOENIX CURVED SECONDARY EMERGENCY VENT
- 2" FPT PHOENIX FLAT STAGE 1 VAPOR RECOVERY / STICK / GAUGE
- 2" FPT PHOENIX FLAT STAGE 1 VAPOR RECOVERY / STICK / GAUGE
- 4" FPT PHOENIX CURVED FILL
- 6" FPT PHOENIX CURVED PRIMARY EMERGENCY VENT
- 2" FPT PHOENIX FLAT NORMAL VENT
- 2" FPT PHOENIX FLAT SPARE / STAGE 2 VAPOR RECOVERY
- 4" FPT PHOENIX CURVED PUMP / DISPENSER

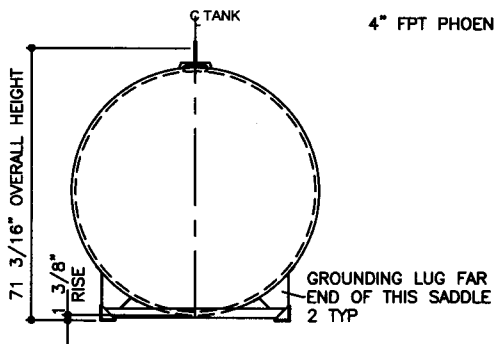

ELEVATION - END VIEW

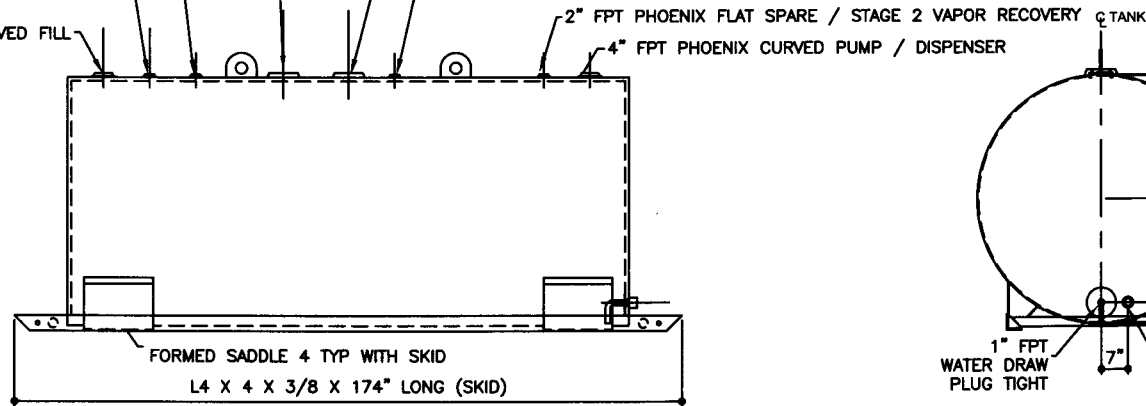

ELEVATION - SIDE VIEW

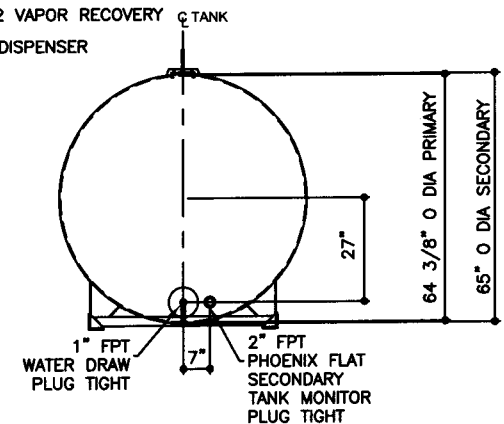

ELEVATION - END VIEW

TOLERANCES	
TANK	
CAPACITY	-0% / +10
OVERALL LENGTH	-0" / +2"
OVERALL WIDTH	-0" / +1"
OVERALL HEIGHT	-1/2" / +1/2"
OTHER DIMENSIONS	-1/4" / +1/4"

UL 142 (BUILT & LABELED)
 HOLDDOWNS ARE SEISMIC RATED
 DOUBLE WALL TANK
 SKID TANK

STEEL: ASTM A36
 PRIMARY TANK
 SHELL: 6 GAUGE (3/16")
 HEAD: 6 GAUGE (3/16")

COATING:
 "R" EXTERIOR COATING, ACE 1A
 RED SHOP COAT 1-3 MILS

"A" EXTERIOR ACE 3A COATING:
 SP-6 GRIT BLAST
 3A COLOR: #WH01 (WHITE)
 1 CT TN-161 EPOXY 3.0-5.0 MILS
 1 CT TN-74 URETHANE 2.0-3.0 MILS
 TDFT 5.0-8.0 MILS

SPECIAL INSTRUCTIONS
 PLUG TIGHT
 WRENCH PLUG TIGHT WITH PIPE DOPE
 ON THREADS AND TESTED LEAK FREE.

APPROXIMATE SHIPPING WEIGHT
 4,040 LBS.

TANK VENT CAPACITY
 211,000 PRIMARY TANK

211,000 SECONDARY TANK

DRW BY
 REV No
 1



1-208-281-5000

AceSkidLite II - 2,000 GALLON

ACE PART No. **AC02000U2K4** QTY: **1**

(102197-F:1111ACSHOPISKIDU2K41020002-ORTHO.GCD-1:32)

SECONDARY TANK
 SHELL: 10 GAUGE (9/64")
 HEAD: 6 GAUGE (3/16")

INTERIOR:
 BARE STEEL

JOB ID No. - ACE HOUSE PAPER No. - ENG. FILE No. -

09-01-01 SUPERCEDES 10-1-00

SHEET
 2
 OF

BILL OF MATERIAL

ITEM	QTY	NAME	DESCRIPTION	MATL	PART No.	NOTES
1	2	SKID	L4 X 4 X 3/8 X 174" LONG	A36	-	MOUNT, COAT
2	2	SKID STIFFENER	1 1/4" SCH. 40 PIPE X 49" LONG	A36	-	MOUNT, COAT
3	-	END CAP	PLATE	-	-	SEE DTL SHT

NOTE:
1. ALL NOMINAL DIMENSIONS ARE 2"±

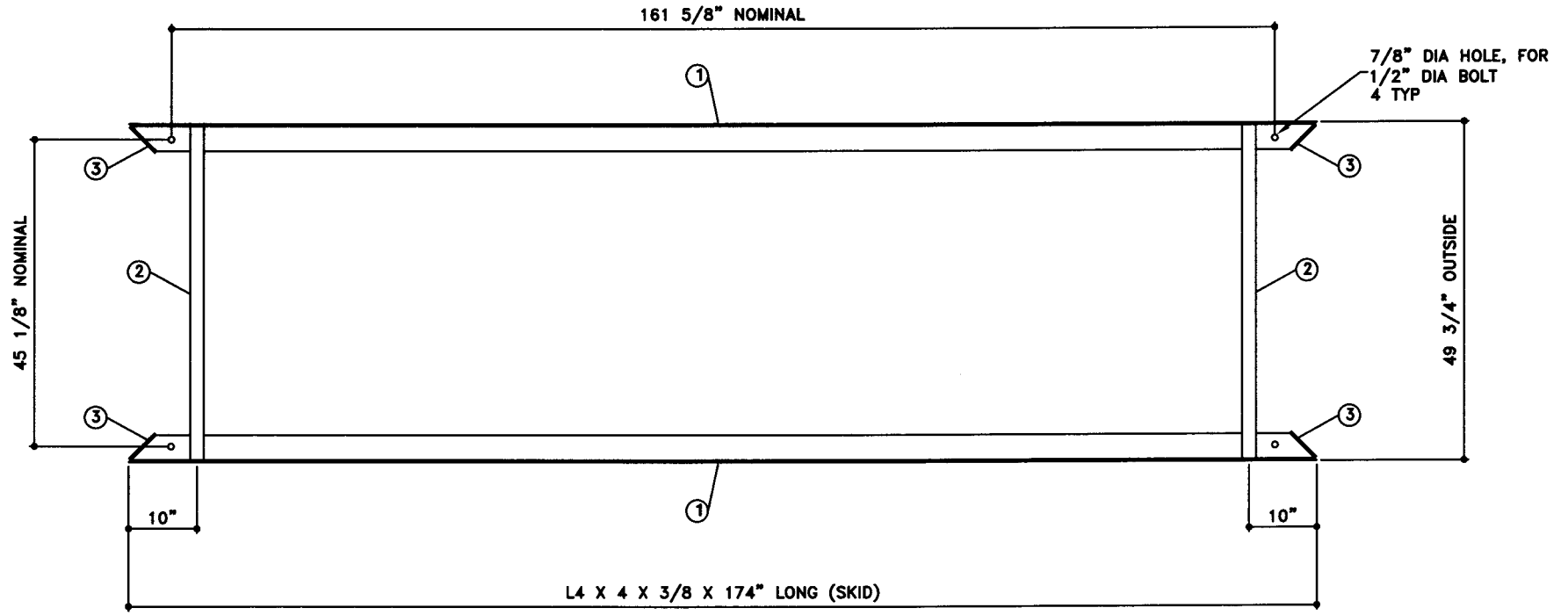

TOP VIEW

JOB ID No.	TOLERANCES	QUANTITY	PART NAME	No.	DRAWING / REVISION	DRAWN BY	CHECKED BY	SHEET
-	SKID	1	SKID DETAILS	1	1ST SUBMITTAL	-	-	OF
ACE HOUSE PAPER No.	OVERALL LENGTH -1/4" / +1/4"			-	-	-	-	
-	OVERALL WIDTH -1/4" / +1/4"			-	-	-	-	
ENGG. FILE No.	OVERALL HEIGHT -1/4" / +1/4"		ACE PART No.	-	-	-	-	
-	OTHER DIMENSIONS -1/8" / +1/8"		(1:16)	-	-	-	-	
			AC02000U2K4		01-01-01 SUPERCEDES			