

ELEVATION - END VIEW

ELEVATION - SIDE VIEW

ELEVATION - END VIEW

<b>TOLERANCES</b> <b>TANK</b> CAPACITY -0% / +10 OVERALL LENGTH -0" / +2" OVERALL WIDTH -0" / +1" OVERALL HEIGHT -1/2" / +1/2" OTHER DIMENSIONS -1/4" / +1/4"		UL 142 (BUILT & LABELED) HOLDDOWNS ARE SEISMIC RATED DOUBLE WALL TANK SKID TANK		STEEL: ASTM A36 PRIMARY TANK SHELL: 2 GAUGE (1/4") HEAD: 2 GAUGE (1/4")		COATING: "R" EXTERIOR COATING, ACE 1A RED SHOP COAT 1-3 MILS  "A" EXTERIOR ACE 3A COATING: SP-6 GRIT BLAST 3A COLOR: #WH01 (WHITE) 1 CT TN-161 EPOXY 3.0-5.0 MILS 1 CT TN-74 URETHANE 2.0-3.0 MILS TDFT 5.0-8.0 MILS		SPECIAL INSTRUCTIONS PLUG TIGHT WRENCH PLUG TIGHT WITH PIPE DOPE ON THREADS AND TESTED LEAK FREE.		APPROXIMATE SHIPPING WEIGHT: 20,000 LBS.  TANK VENT CAPACITY 428,000 PRIMARY TANK  428,000 SECONDARY TANK		DRW BY - REV No 1 SHEET 2 OF
1-206-281-5000 		<b>AceSkidLite II - 12,000 GALLON</b>		SECONDARY TANK SHELL: 6 GAUGE (3/16") HEAD: 2 GAUGE (1/4")		INTERIOR: BARE STEEL		JOB ID No. - ACE HOUSE PAPER No. - ENG. FILE No. - 01-01-02 SUPERCEDES 09-01-01		QTY: 1		

### BILL OF MATERIAL

ITEM	QTY	NAME	DESCRIPTION	MATL	PART No.	NOTES
1	2	SKID	W8 X 21 X 428" LONG	A36	-	-
2	3	SKID CROSS BRACE	4" SCH. 40 PIPE X 68 1/2" LONG	A36	-	-
3	-	TOW EYE	TYPE 2 LIFT LUG	A36	-	-
4	-	HOLDDOWN	-	A36	-	SEE DTL SHT
5	-	SKID CAP	-	A36	-	SEE DTL SHT

NOTE:  
1. ALL NOMINAL DIMENSIONS ARE 3"±

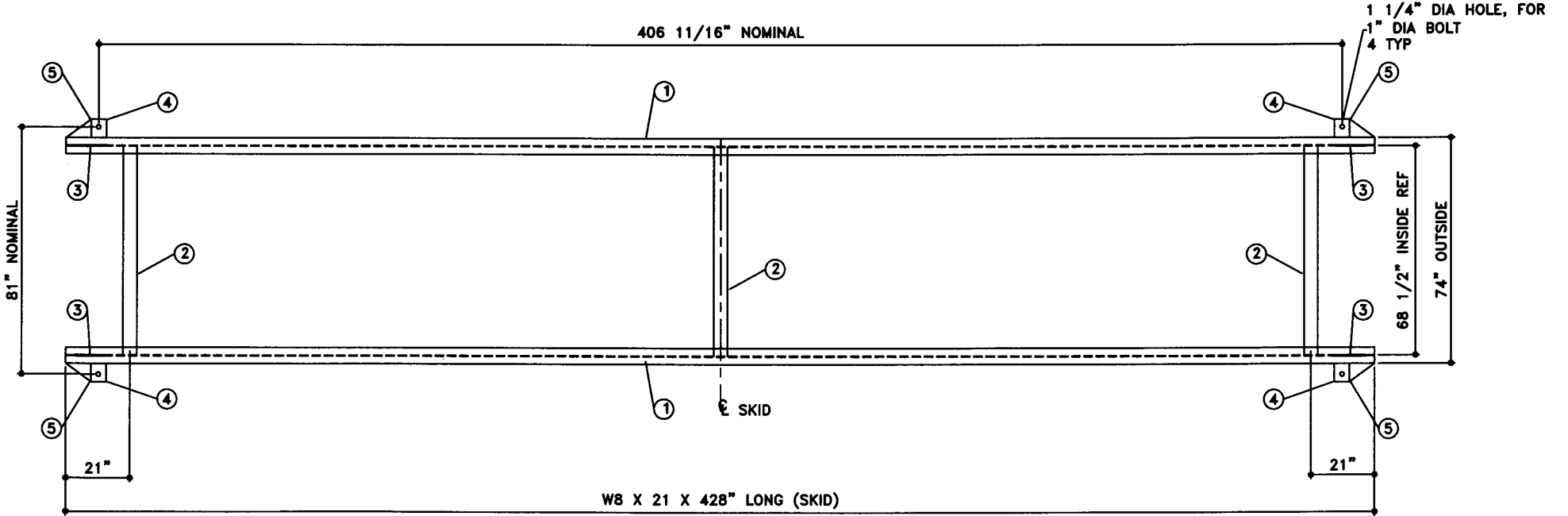

TOP VIEW

JOB ID No.	TOLERANCES
-	SKID
ACE HOUSE PAPER No.	OVERALL LENGTH -1/4" / +1/4"
-	OVERALL WIDTH -1/4" / +1/4"
ENGG. FILE No.	OVERALL HEIGHT -1/4" / +1/4"
-	OTHER DIMENSIONS -1/8" / +1/8"

QUANTITY	PART NAME
1	SKID DETAILS
	ACE PART No. AC12000U2K4
	(1:32)

No.	DRAWING / REVISION	DRAWN BY	CHECKED BY	SHEET
1	1ST SUBMITTAL	-	-	OF
-	-	-	-	-
-	-	-	-	-
-	-	-	-	-
-	-	-	-	-
01-01-01 SUPERCEDES				