

TOP VIEW

- 4" FPT PHOENIX CURVED PRIMARY EMERGENCY VENT
- 4" FPT HALF COUPLING SECONDARY EMERGENCY VENT
- 2" FPT PHOENIX FLAT GAUGE / STICK / STAGE 1 VAPOR RECOVERY
- 2" FPT PHOENIX FLAT STICK / GAUGE / STAGE 1 VAPOR RECOVERY
- 4" FPT, FULL COUPLING PRODUCT FILL
- 2" FPT PHOENIX FLAT NORMAL VENT
- 2" FPT PHOENIX FLAT SPARE / STAGE 2, VAPOR RECOVERY
- 4" FPT PHOENIX CURVED PUMP/DISPENSER

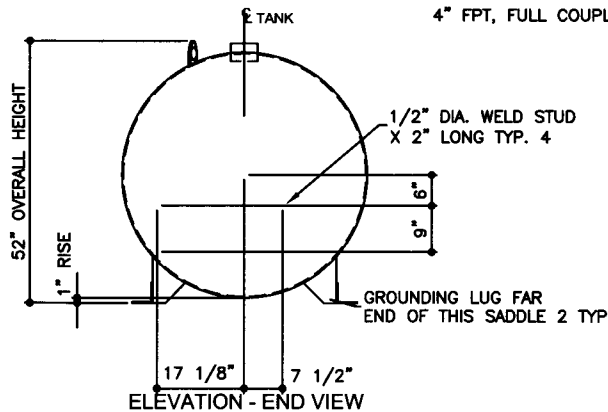

ELEVATION - END VIEW

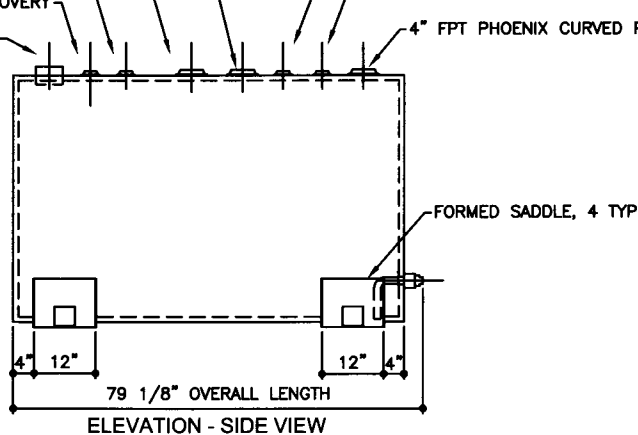

ELEVATION - SIDE VIEW

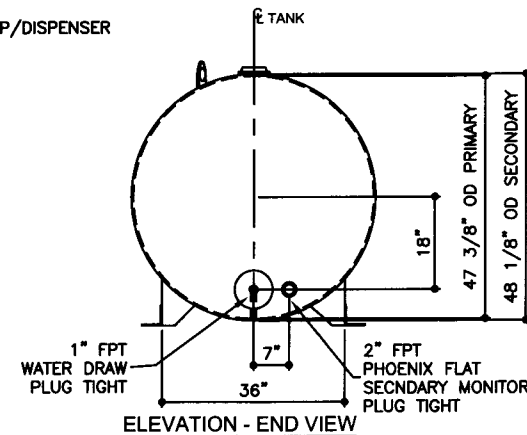

ELEVATION - END VIEW

**TOLERANCES**

**TANK**

CAPACITY	-0% / +10
OVERALL LENGTH	-0" / +2"
OVERALL WIDTH	-0" / +1"
OVERALL HEIGHT	-1/2" / +1/2"
OTHER DIMENSIONS	-1/4" / +1/4"

UL 142 (BUILT & LABELED)  
HOLDDOWNS ARE SEISMIC RATED  
DOUBLE WALL TANK  
SADDLE TANK

STEEL: ASTM A36  
PRIMARY TANK  
SHELL: 12 GAUGE (7/64")  
HEAD: 12 GAUGE (7/64")

COATING:  
"R" EXTERIOR COATING, ACE 1A  
RED SHOP COAT 1-3 MILS

"A" EXTERIOR ACE 3A COATING:  
SP-6 GRIT BLAST  
3A COLOR: #WH01 (WHITE)  
1 CT TN-161 EPOXY 3.0-5.0 MILS  
1 CT TN-74 URETHANE 2.0-3.0 MILS  
TDFT 5.0-8.0 MILS

**SPECIAL INSTRUCTIONS**

PLUG TIGHT  
WRENCH PLUG TIGHT WITH PIPE DOPE  
ON THREADS AND TESTED LEAK FREE.

APPROXIMATE SHIPPING WEIGHT  
1,100 LBS.

TANK VENT CAPACITY  
84,200 PRIMARY TANK  
84,200 SECONDARY TANK

JOB ID No.	ACE HOUSE PAPER No.	ENG. FILE No.
-	-	-

04-01-02 SUPERCEDES 01-01-02

DRW BY  
REV No  
1  
SHEET  
2  
OF

**AceSaddleLite II - 550 GALLON**

ACE PART No. AC00550U2S4 QTY: 1

SECONDARY TANK  
SHELL: 12 GAUGE (7/64")  
HEAD: 10 GAUGE (9/64")

INTERIOR:  
BARE STEEL

(F:111)ACSHOPISADDLEIU2S4100550U2-ORTHO.GCD-1:24)

